

HyperFront Axle assembly 100x9mm / QR15

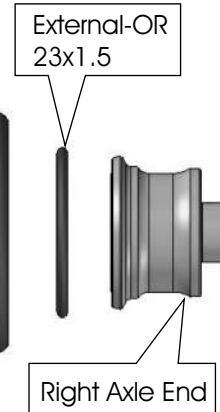
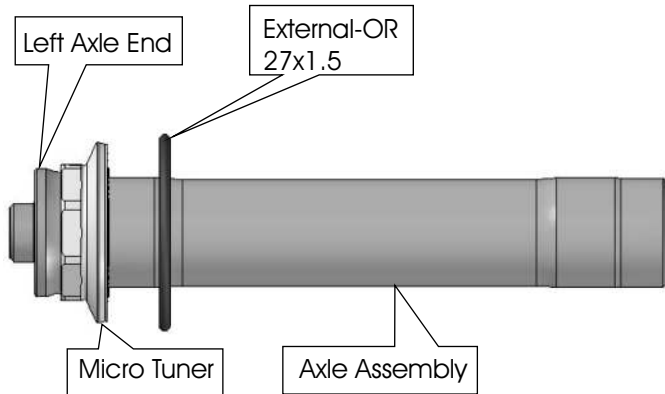

Disassembly and cleaning.

- 1) Pop out Right Axle End with External OR (23x1.5)
- 2) Extract Axle Assembly and External OR (27x1.5) from right side.
- 3) Clean hub internals and all parts (Do not use aggressive solvents).

Reassembly.

- 4) Apply grease on new Axle Assembly bearing contact areas.
- 5) Fill up Micro Tuner internal face with soft grease.
- 6) Insert new Axle Assembly from Left side, gently push it in with using the small plastic mallet.
- 7) Fill up Right Axle End internal face with soft grease.
- 8) Gently pop in Right Axle End with the plastic mallet while Left Axle End is rested against a wood or plastic surface.
- 9) Check Preload Tuning (see Bearing Set-Up chapter).
- 10) Install External OR (27x1.5 oiled) between Micro Tuner and bearing.
- 11) Install External OR (23x1.5 oiled) between Right Axle End and bearing.

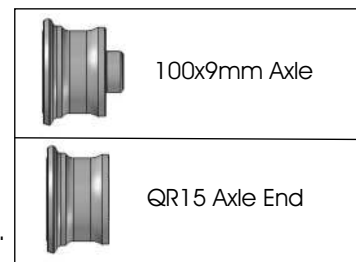

Warning: install External Orings only when the hub is completely assembled and tuned.

Warning: water and moisture stagnant inside hub will damage bearings in few weeks.

BEARING PRELOAD SET-UP:

Optimal bearing preload is important for a long bearing life.

Checking

Before modifying bearing preload carefully check the complete wheel as follows:

- 1) Install wheel into dropouts and normally lock skewer.
- 2) Check there is no play at rim diameter.
- 3) Leave wheel free to completely stop spinning and carefully control latest instants of movement. Stopping should be very smooth.

Preload Tuning

If necessary fine tune as follows.

- 1) Install wheel into dropouts and normally lock skewer.
- 2) If you feel play at the rim turn in Micro-Tuner (clockwise). Use a 21mm wrench, very delicate torque and manners.
- 3) Unscrew Micro-Tuner for ca 1/4 of turn to release excessive preload on bearing balls and achieve max rolling smoothness.
- 4) Repeat Preload Checking and eventually slightly correct it.
- 5) The optimal bearing preload cancels play at the rim without affecting rolling smoothness.

Warning Incorrect bearing preload can damage bearings and freewheel parts additionally decreases hub performance.

SEALING HyperRear hub features low friction external OR seals. However, since it is impossible to completely seal a hub and still have it spin freely, with use water/moisture can get in.

GUIDELINE Periodically clean hub internals (every 6-12 months in normal and dry conditions, every 3 months in wet conditions and always before leaving the wheel un-used for more than 1 month).

Never use high-pressure spray washing directly on hubs. Clean hubs externally with warm water and soap.

WARNING Water and moisture stagnant inside hub can permanently damage bearings.