

HyperRear HyperCamber

**Freewheel Kit replacement
Shimano/Sram or Sram XD Drive**

WARNING: Execute these operations only on a well clean and well illuminated table, you'll have to handle delicate internal parts and tiny springs, even small debris can compromise freewheel engagement mechanism.
Carefully follow maintenance instructions step by step.
Schedule periodical cleaning and lubrication sessions since water and moisture stagnant inside hub will damage bearings in few weeks.

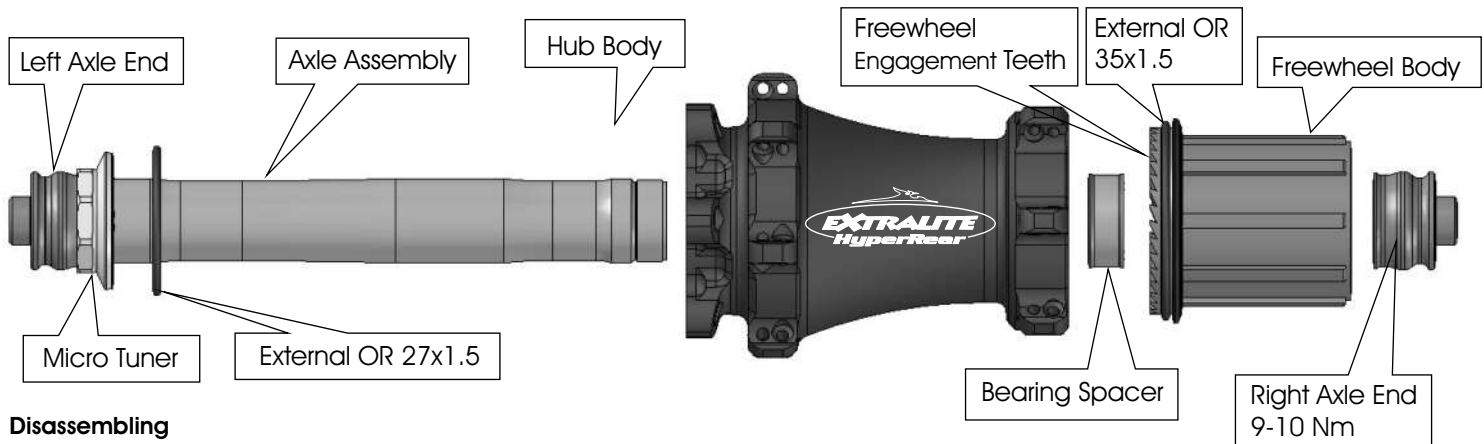

Disassembling

- 1) Insert a 5mm hex wrench into Left Axle End (17mm closed wrench for QR12).
- 2) Unscrew Right Axle End with another 5mm hex wrench (17mm closed wrench for QR12).
- 3) Pull Freewheel Body and remove it.
- 4) Extract Bearing Spacer.
- 5) Remove Retainer Ring from Hub Body.
- 6) Remove Floating Ring from Hub Body, you'll find 3 tiny springs on its back side.
- 7) Push out Axle Assembly and completely extract it from disc side.

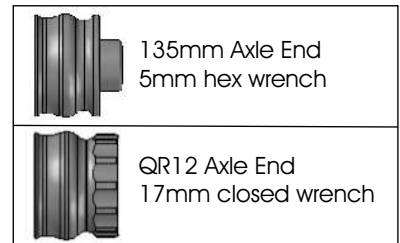

Cleaning

- 8) Clean all parts (Do not use aggressive solvents).
- 9) Clean very carefully all Internal Splines.

Warning: even one small debris can void freewheel engagement.

Warning: carefully check hubshell Splines (see below).

Checking hubshell Splines

Once hub-shell internal is perfectly clean check well that every spline corner is still well square and flat.

When riding HyperRear / HyperCamber with dirt inside the hard particles of sand can sensibly grind the hubshell splines. Shortly the sand grinds and rounds all the hub-shell splines till the "floating ring" won't move freely anymore. In this case replacing "floating ring" and/or "Freewheel body" will not solve. It's required to replace the expensive hub-shell.

For more detailed informations check HyperHubs Tips on www.extralite.com

Never install new freewheel parts on a worn-out hub-shell.
Carefully check that all the corners of hubshell splines are still well square and in good shape (not rounded nor worn-out). Worn and rounded Spline corners will void the quick and free movement of floating-ring. This easily causes an uncomplete freewheel engagement and damages permanently the newly installed freewheel parts.

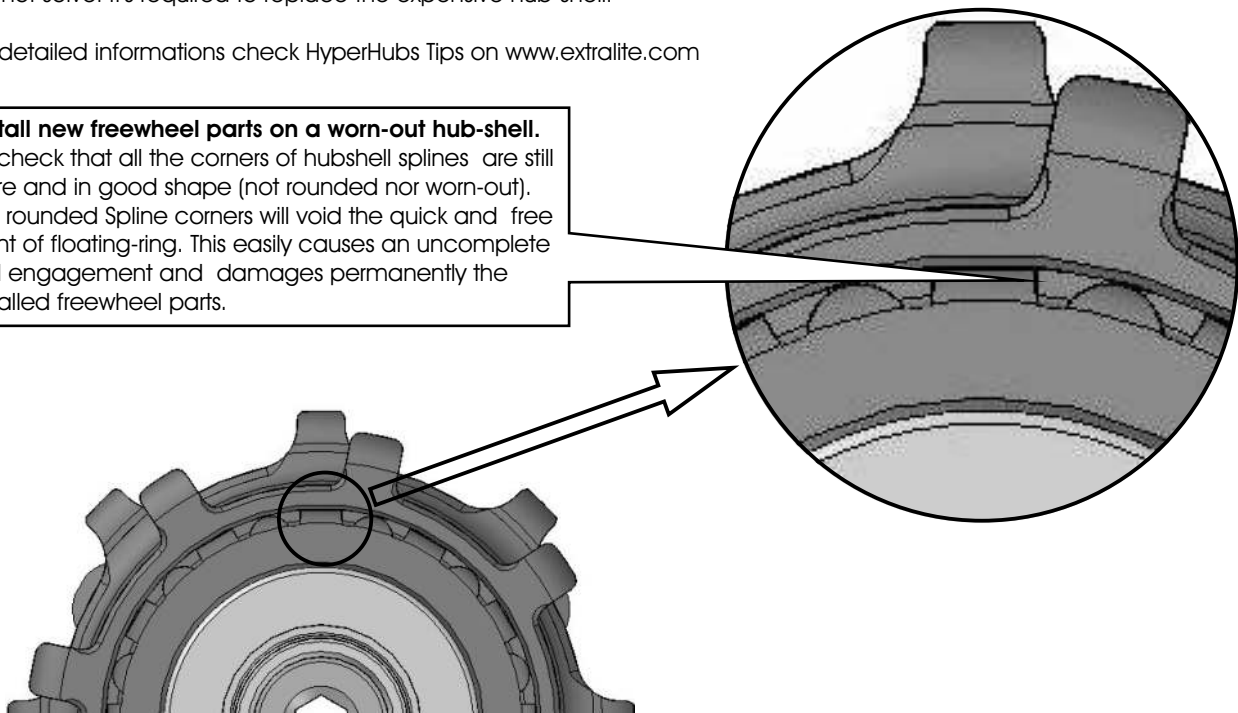

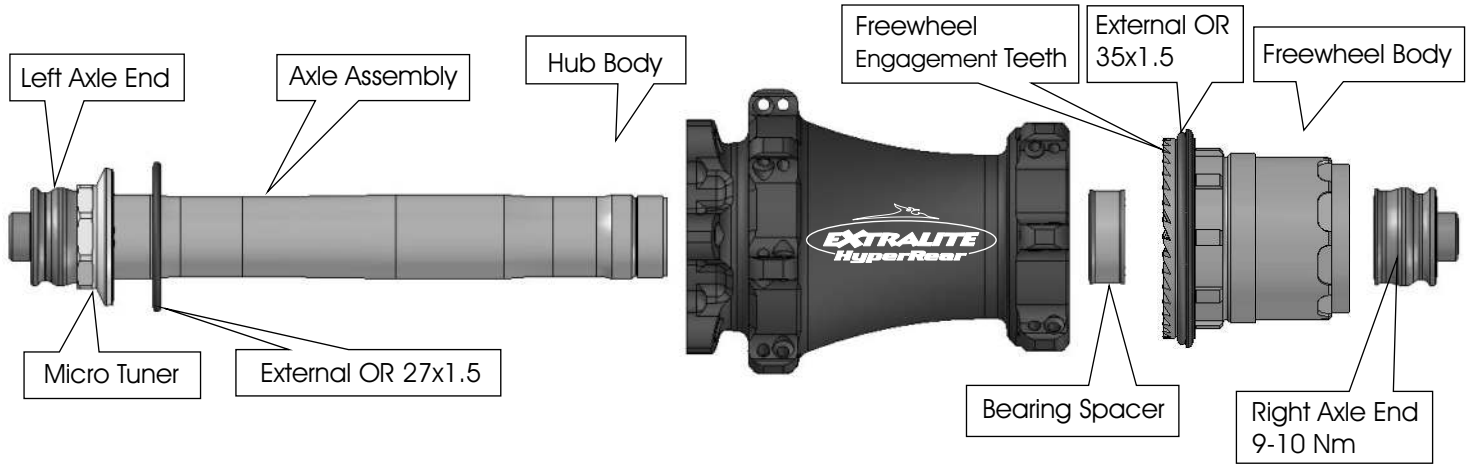

Reassembling and lubrication

Warning: use only very soft density grease as original Alugrease Super1. Medium-dense or sticky grease can lock or slow down Floating Ring movement, this can destroy the freewheel mechanism! Chemical additives may damage O-rings.

- 10) Grease Axle on bearing contact areas.
- 11) Fill up Micro Tuner internal face with soft grease.
- 12) Insert Axle Assembly from disc side.
- 13) Insert Bearing Spacer.
- 14) Oil Internal Splines of Hub Body with 1 cc w30-50 motor oil.
- 15) Apply a minimal amount of grease into spring fitting holes on Floating Ring back side, then carefully insert the 3 springs.
- 16) Insert Floating Ring (check again that the 3 springs are in their correct position).
- 17) Fully snap in Retainer Ring (uncomplete/unaligned inserting voids OR seal function)
- 18) Check that Floating Ring moves freely and quickly.
- 19) Apply 1 cc of soft grease onto Freewheel Engagement Teeth.
- 20) Insert New Freewheel Body with External OR in position.
- 21) Tighten Right Axle End at 9-10 Nm.
- 22) Check Preload Tuning (see chapter).
- 23) Install External OR (27x1.5 oiled) between Micro Tuner and bearing.

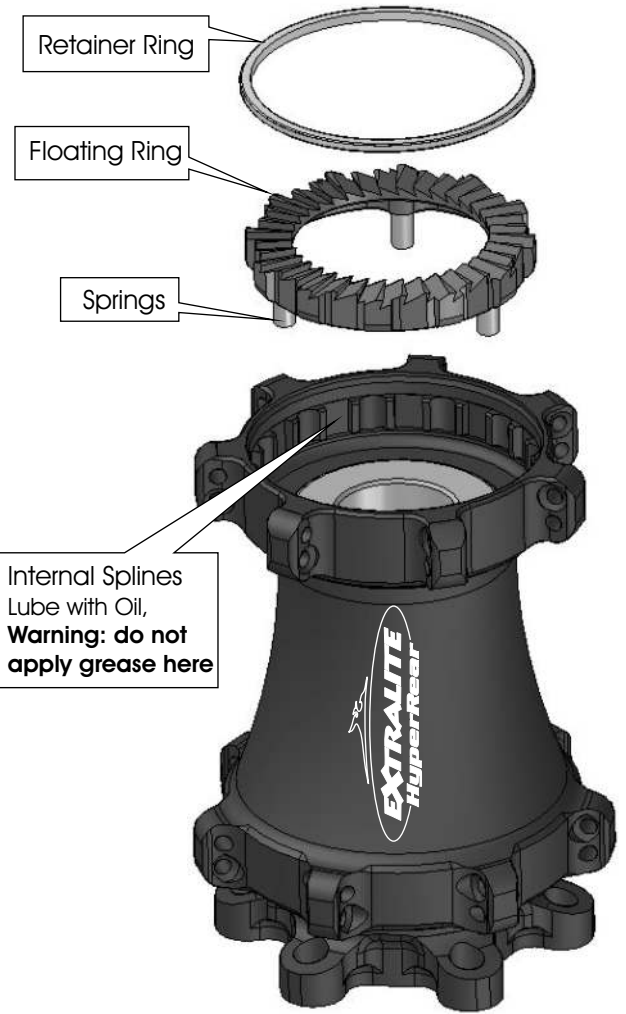

Extralite Limited Warranty

Extralite products are warranted against defects in materials and/or workmanship for a period of two years from original date of purchase to the original owner only. Any Extralite product that is returned and found by Studio Riva to be defective in materials and/or workmanship will be repaired or replaced at the sole discretion of Studio Riva. This warranty is the sole and exclusive remedy. Studio Riva shall not be held liable for any indirect, special or consequential damages. The warranty is expressly limited to repair or replacement of the product that has been returned and found to be defective by Studio Riva and are the sole remedy of the warranty. No credits or refunds will be issued.

The warranty does not cover: normal wear, tear and fatigue; damage or failure due to accident or collision. Improper assembling, poor maintenance, alterations or modifications, installation of parts not compatible with Extralite products void this warranty. Warranty does not cover damage arising from crash, abuse and/or misuse or any other circumstances in which the product had been subjected to forces or loads beyond its design.

Immediately replace the component after crash and violent shock, or after continuous heavy use.
 Improper use, modification and/or part changing, including surface finishing, could irreparably damage the component.
 All labor charges for warranty service are responsibility of the product owner.

INSTALLATION WARNING:

Extralite components are extremely performing and lightweight, crafted with very high quality, they request adequate installation and maintenance care. We strongly recommended that a professional bike shop install and service your Extralite components.

Improper assembly and/or adjustment may significantly compromise strength and durability of the component causing serious personal injury. Carefully check proper tightening torque of every bolt. Always respect installation recommendations.

Extralite components are designed for a specific use X-Country or Road or Downhill, respect product specific destination.
 Note: the rider assumes all the risks regarding use and installation of Extralite components.