

E-Bones W PF41

Read carefully instruction before installation

FRAME PREPARATION

Prepare BB shell:

1) BB shell faces should be parallel, $\pm 0.05\text{mm}$ tolerance.

2) BB shell faces should be at $89.5 -0 +0.5\text{mm}$.

Eventually file faces with appropriate tool.

3) Make a 0.5mm chamfer at 41mm BB diameter.

4) Moisture draining: drill $\varnothing 3.5$ to 5mm drain hole.

Stagnant moisture or water will damage bearings in few weeks.

Drilling might be not necessary only on sealed BB shell of monocoque frames.

WARNING: Uncorrect / incomplete 1,2,3 set-ups can significantly reduce bearing life and performance.

DRIVE CRANK PREPARATION

Assemble chainrings on the right crank.

On 3x9 MTB models apply granny spacers (orange) between 22 chainring and spider (pict.1).

Respect chainring alignment marks for correct shifting performance.

FEATURES

Compatibility:

BB 91-41A 89.5mm to 90mm wide bb shell (41mm bore)

Chainline: 51.2mm

Q-Factor: 165mm

Destination: X-Country use.

SSP
Stress Split Profile
int. pat. pending

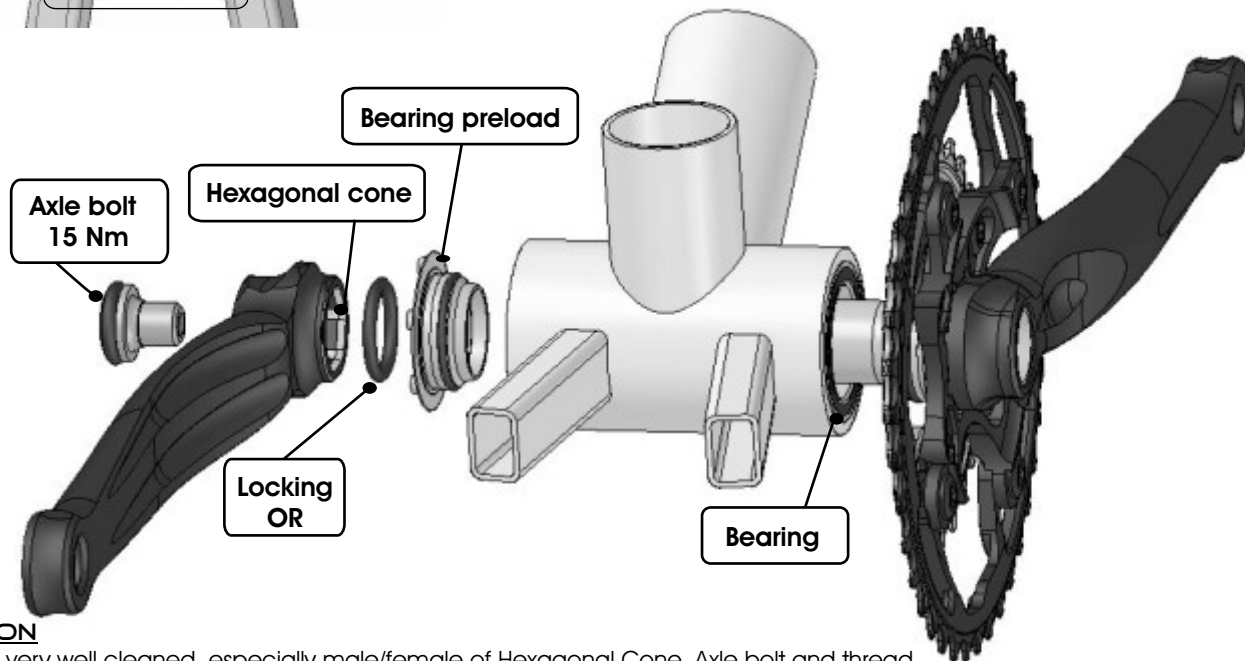
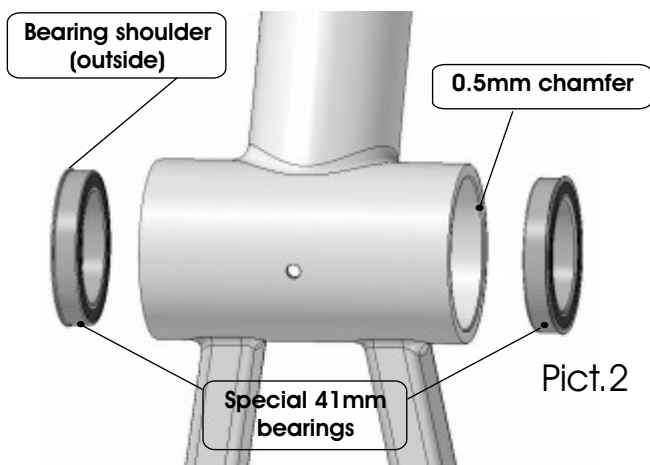
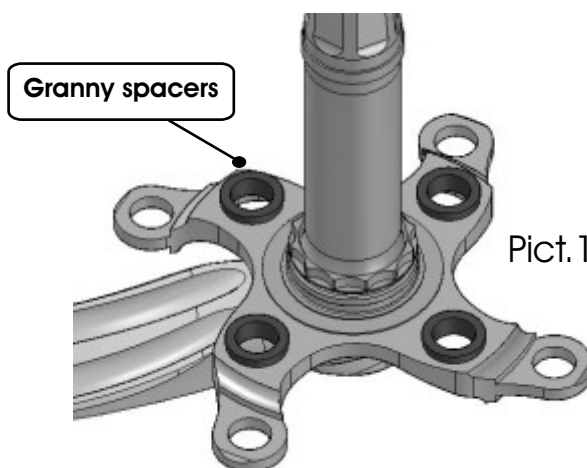

INSTALLATION

Check all parts very well cleaned, especially male/female of Hexagonal Cone, Axle bolt and thread.

1) Install Bearings by gently hammering with a plastic mallet (pict.2).

2) Check bearings outside faces: should be at 89.5-90mm and parallel ($\pm 0.05\text{mm}$ tolerance).

3) Grease threads, bearings contact areas and Hexagonal cone.

4) Insert right crank axle through bearings.

5) Fully turn in (counterclockwise) bearing preloader (FIRM direction) by hand, then loose it (clockwise) 1/4 to 1/2 turn.

6) Insert Locking OR on axle.

7) Align left crank on axle, grease bolt head contact area and tight it (15Nm).

8) Check bearing preload (see next page).

BEARINGS PRELOAD

Bearing preloader allows you to adjust axial preloading. Use supplied tool to adjust preloader after complete crank assembling.

Use it as follows:

<-- FIRM to correct axial play.

LOOSE --> to increase rolling smoothness.

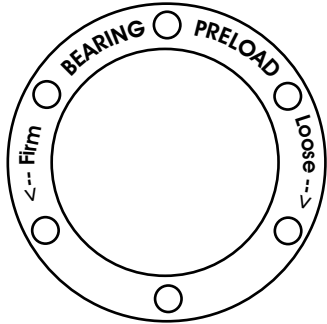

Shake crank-end to check BB play. Optimal tuning cancels axial play without adding any rolling resistance.

WARNING: incorrect bearing preload may seriously damage bearings/parts and decreases performance.

REMOVAL

To disassemble crankset proceed as follows:
Unscrew axle bolt. Remove left crank using ISIS type extractor only. **WARNING: JIS extractors may damage axle thread!**
Fully unscrew (clockwise) Bearing preloader (Loose direction).
Extract right crank and axle.

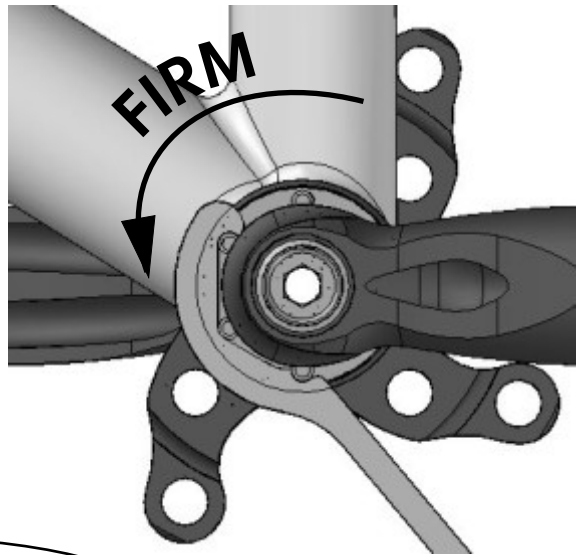
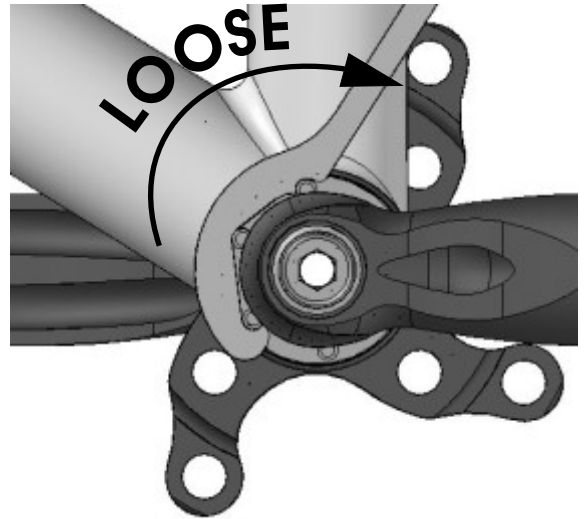

EXTRALITE

Extralite Limited Warranty

Extralite products are warranted against defects in materials and/or workmanship for a period of two years from original date of purchase to the original owner only.

Any Extralite product that is returned and found by Studio Riva to be defective in materials and/or workmanship will be repaired or replaced at the sole discretion of Studio Riva. This warranty is the sole and exclusive remedy.

Studio Riva shall not be held liable for any indirect, special or consequential damages.

The warranty is expressly limited to repair or replacement of the product that has been returned and found to be defective by Studio Riva and are the sole remedy of the warranty. No credits or refunds will be issued.

The warranty does not cover: normal wear, tear and fatigue; damage or failure due to accident or collision. Improper assembling, poor maintenance, alterations or modifications, installation of parts not compatible with Extralite products void this warranty.

Warranty does not cover damage arising from crash, abuse and/or misuse or any other circumstances in which the product had been subjected to forces or loads beyond its design.

Immediately replace the component after crash and violent shock, or after continuous heavy use.

Improper use, modification and/or part changing, including surface finishing, could irreparably damage the component.

All labor charges for warranty service are responsibility of the product owner.

INSTALLATION WARNING:

Extralite components are extremely performing and lightweight, crafted with very high quality, they request adequate installation and maintenance care.

We strongly recommended that a professional bike shop install and service your Extralite components.

Improper assembly and/or adjustment may significantly compromise strength and durability of the component causing serious personal injury.

Carefully check proper tightening torque of every bolt.

Always respect installation recommendations.

Extralite components are designed for a specific use X-Country or Road or Downhill, respect product specific destination.

Note: the rider assumes all the risks regarding use and installation of Extralite components.