

E-Bones W SW-OS

Read carefully instruction before installation

FEATURES

Weight: 498gr. (Set)

Compatibility: Specialized S-Works oversize.

Chainline: 48.7mm

Q-Factor: 160mm

Destination: X-Country use.

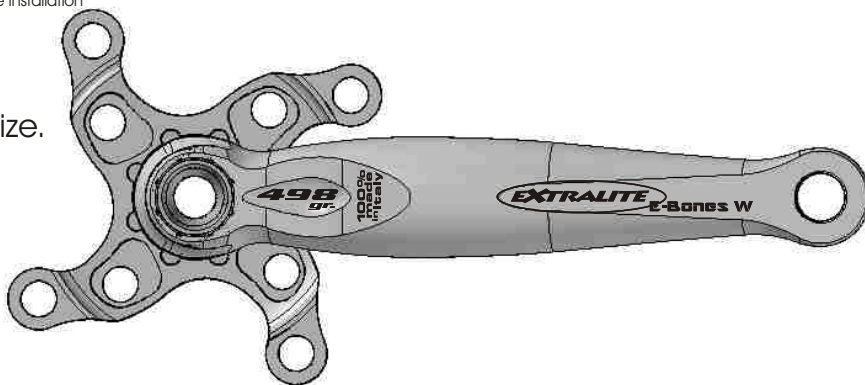

FRAME PREPARATION

1) Make sure that seegers are properly installed inside BB shell grooves.

2) Moisture draining: drill \varnothing 3.5 to 5mm drain hole.

Drilling might be not necessary on sealed BB shell of monocoque frames.

Uncorrect / incomplete 1,2 set-ups can significantly reduce bearing life and performance.

DRIVE CRANK PREPARATION

Assemble chainrings on the right crank.

On 3x9 MTB models apply granny spacers (orange) between 22 chainring and spider (pict.1).

Respect chainring alignment marks for correct shifting performance.

Granny spacers

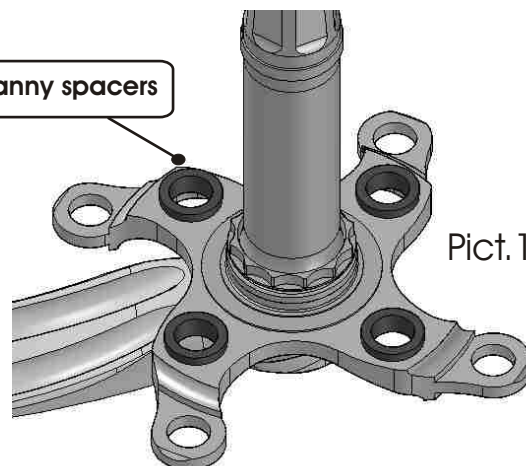

Pict. 1

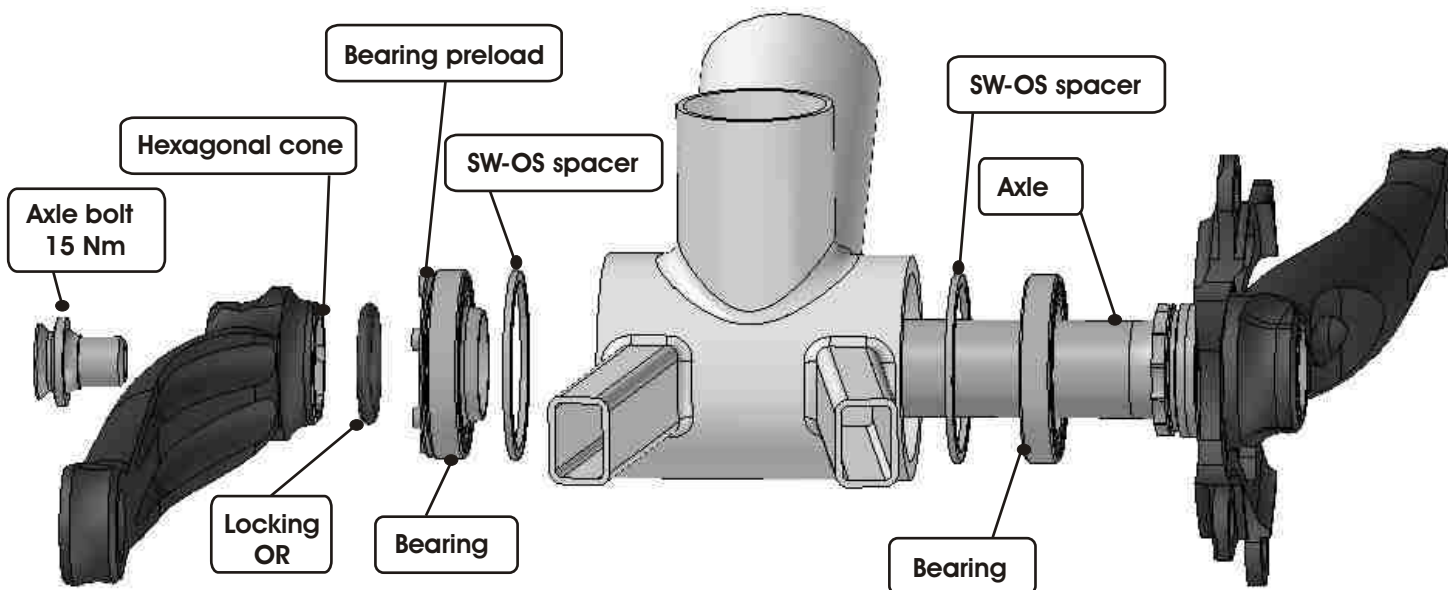

INSTALLATION

Insert left & right SW-OS spacers inside BB shell in contact with seegers (see frame preparation).

Install Bearings using a common headset installation tool with the supplied Mounting Rings to protect bearing races. Position Mounting Rings (flat sides outward) between bearings and the headset installation tool.

Press-fit Bearings. Remove Mounting Rings.

Grease threads, bearings contact areas and Hexagonal cone.

Insert right crank axle through bearings.

Fully turn in (counterclockwise) bearing preloader (FIRM direction) by hand, then loose it (clockwise) 1/4 to 1/2 turn.

Insert Locking OR on axle.

Align left crank on axle, grease bolt head contact area and tight it (15Nm).

Check bearing preload (see next page).

Studio Riva Srl - Tel: ++39-0371-203059 - Fax: ++39-0371-203754
email: studioriva@extralite.com - www.extralite.com

EXTRALITE

BEARINGS PRELOAD

Bearing preloader allows you to adjust axial preloading.
Use supplied tool to adjust preloader after complete crank assembling.

Use it as follows:

<-- FIRM to correct axial play.

LOOSE --> to increase rolling smoothness.

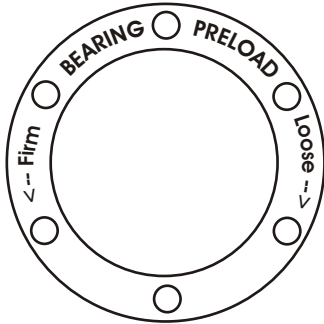

Shake crank-end to check BB play.

Optimal tuning cancels axial play without adding any rolling resistance.

WARNING: incorrect bearing preload may seriously damage bearings/parts and decreases performance.

REMOVAL

To disassemble crankset proceed as follows:

Unscrew axle bolt. Remove left crank using ISIS type extractor only. **WARNING: JIS extractors may damage axle thread!**

Fully unscrew (clockwise) Bearing preloader (Loose direction).
Extract right crank and axle.

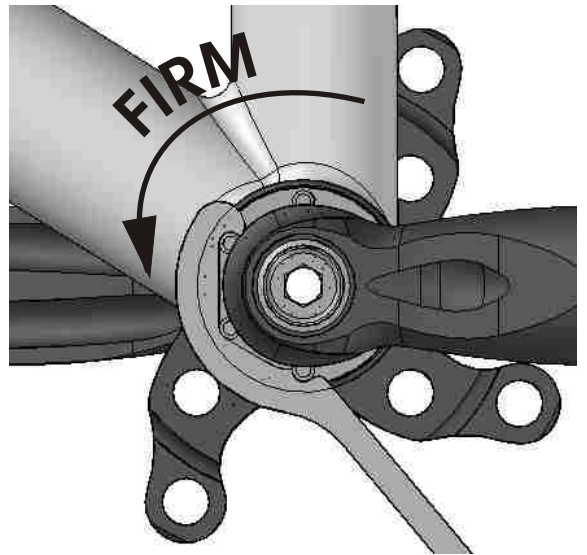
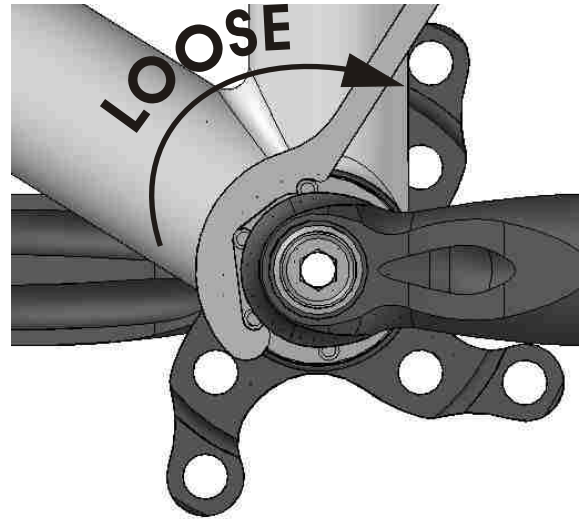

Studio Riva Srl - Tel: ++39-0371-203059 - Fax: ++39-0371-203754
email: studioriva@extralite.com - www.extralite.com

EXTRALITE