

# E-Bones WR/RC

BSA 68mm

ITA 70mm

Read carefully instruction before installation

## FEATURES

Weight: 496gr. (WRC)

502gr. (WR)

Compatibility: BSA 68mm BB shell.

BCD: standard 110mm (WRC)

standard 130mm (WR)

Chainline: 44mm

Q-Factor: 160mm

**SSP**

Stress Split Profile

int. pat. pending

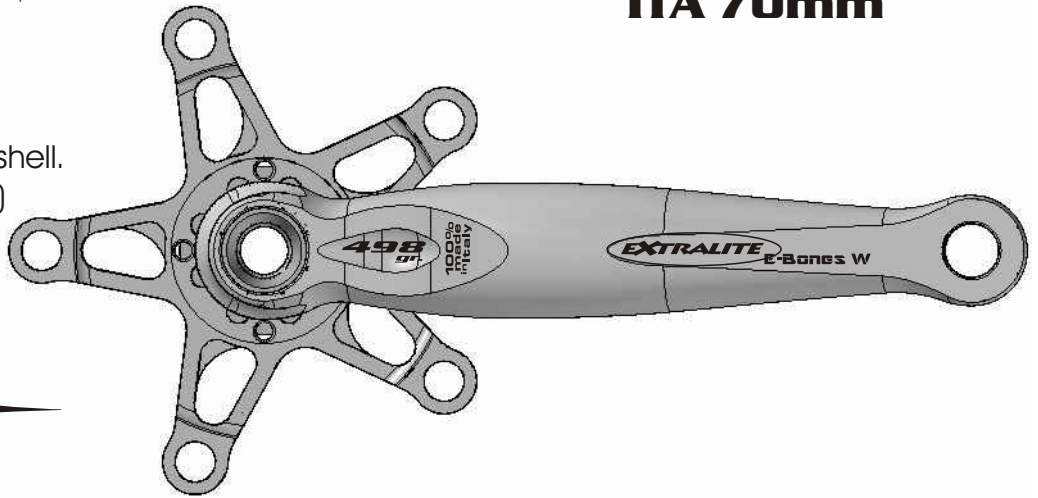

## FRAME PREPARATION

Prepare BB shell:

1) BB shell faces should be parallel,  $\pm 0.05\text{mm}$  tolerance.

2) BB shell faces should be at  $68 \pm 0.2\text{mm}$ .

Eventually file faces with appropriate tool.

3) Moisture draining: drill  $\varnothing 3.5$  to 5mm drain hole.

Drilling might be not necessary on sealed BB shell of monocoque frames.

Uncorrect / incomplete 1,2,3 set-ups can significantly reduce bearing life and performance.

## DRIVE CRANK PREPARATION

Assemble chainrings on the right crank.

Respect chainring alignment marks for correct shifting performance.

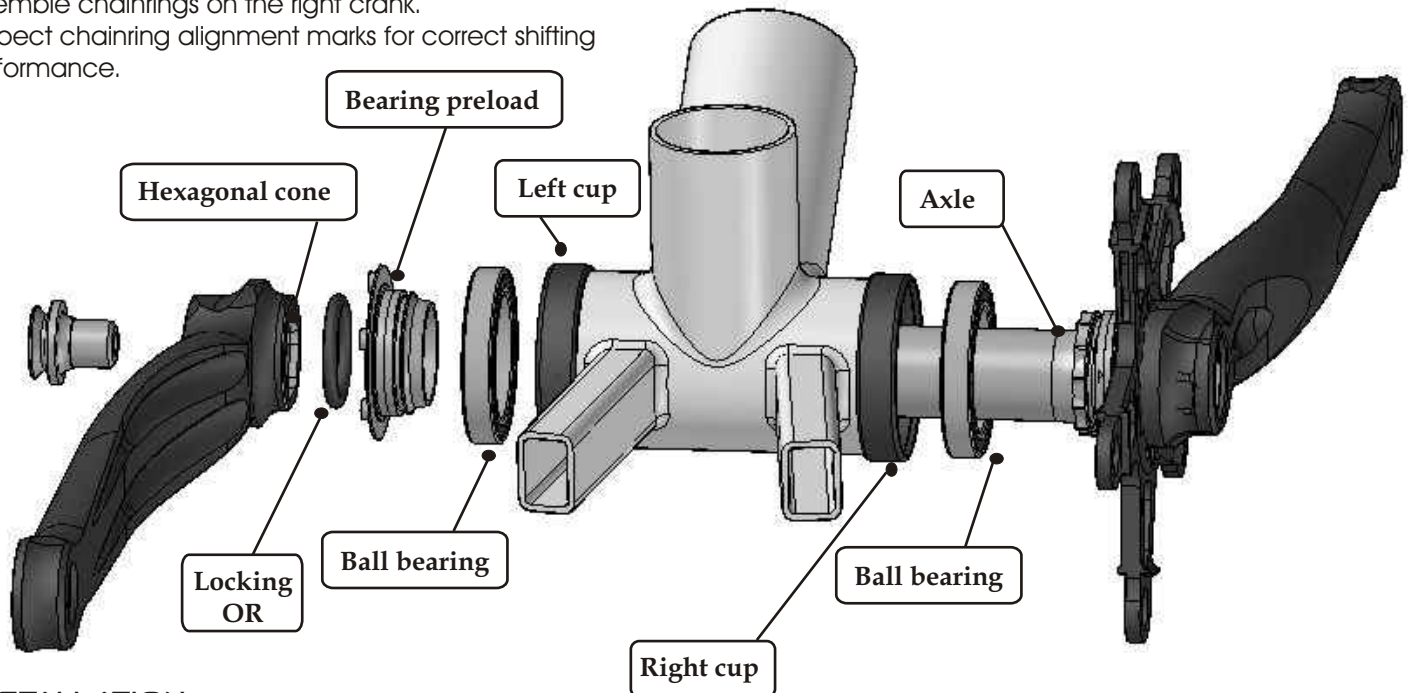

## INSTALLATION

Tight right side cup counterclockwise (20Nm) on BB shell with Shimano TL-UN70 tool.

Tight left side cup clockwise (20Nm) on BB shell with Shimano TL-UN70 tool.

Snap left & right BB bearings into cups by hand.

Grease threads, bearings contact areas and Hexagonal cone.

Insert right crank axle through bearings.

Fully turn in (counterclockwise) bearing preloader (FIRM direction) by hand, then loose it (clockwise) 1/4 to 1/2 turn.

Insert Locking OR on axle.

Align left crank on axle, grease bolt head contact area and tight it (15Nm).

Check bearing preload (see next page).

Studio Riva Srl - Tel: ++39-0371-203059 - Fax: ++39-0371-203754  
email: [studioriva@extralite.com](mailto:studioriva@extralite.com) - [www.extralite.com](http://www.extralite.com)

**EXTRALITE**

## BEARINGS PRELOAD

Bearing preloader allows you to adjust axial preloading. Use supplied tool to adjust preloader after complete crank assembling.

Use it as follows:

<-- FIRM to correct axial play.

LOOSE --> to increase rolling smoothness.

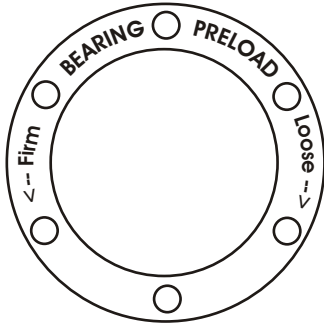

Shake crank-end to check BB play.

Optimal tuning cancels axial play without adding any rolling resistance.

**WARNING:** incorrect bearing preload may seriously damage bearings/parts and decreases performance.

## REMOVAL

To disassemble crankset proceed as follows:

Unscrew axle bolt. Remove left crank using ISIS type extractor only. **WARNING: JIS extractors may damage axle thread!**

Fully unscrew (clockwise) Bearing preloader (Loose direction). Extract right crank and axle.

Spare bearings are available at Extralite, contact us for any question.

