

Ultra Rear SPX Version 2.0

WARNING:

- 1) Incorrect bearing preload may seriously damage bearings/parts and decreases performance.
 - 2) Never use high-pressure spray washing directly on bearings / Freewheel. Clean hubs externally with warm water and soap.
 - 3) Water and moisture (stagnant in hub body) can permanently damage bearings / freewheel parts.
- Destination: Road use only.

SPOKE TENSION:

Never exceed rim manufacturer recommended maximum tension.

Maximum spoke tension:

Drive Side 130Kgf +/- 10Kgf.

Left Side 80Kgf +/- 10Kgf.

BEARING SET-UP

Bearings come pre-adjusted from the factory. Optimal preload is important for long bearing life.

Preload checking

Before modifying bearing preload carefully check the complete wheel as follows:

- 1) Install the complete wheel into dropouts and normally lock skewer.
- 2) Check there is no play at rim diameter.
- 3) Leave wheel free to completely stop spinning and carefully control latest instants of movement. Stopping should be very smooth.

Micro-Tuner



Preload tuning

If necessary fine tune as follows; no tools are required.

- 1) Hold right axle end with one hand and turn Micro-Tuner fully clockwise by hand.
- 2) Unscrew Micro-Tuner for 1/8 to 1/4 of turn.
- 3) Repeat preload checking and eventually slightly correct it. Turn anti-clockwise to increase rolling and stopping smoothness. Turn clockwise to correct play.

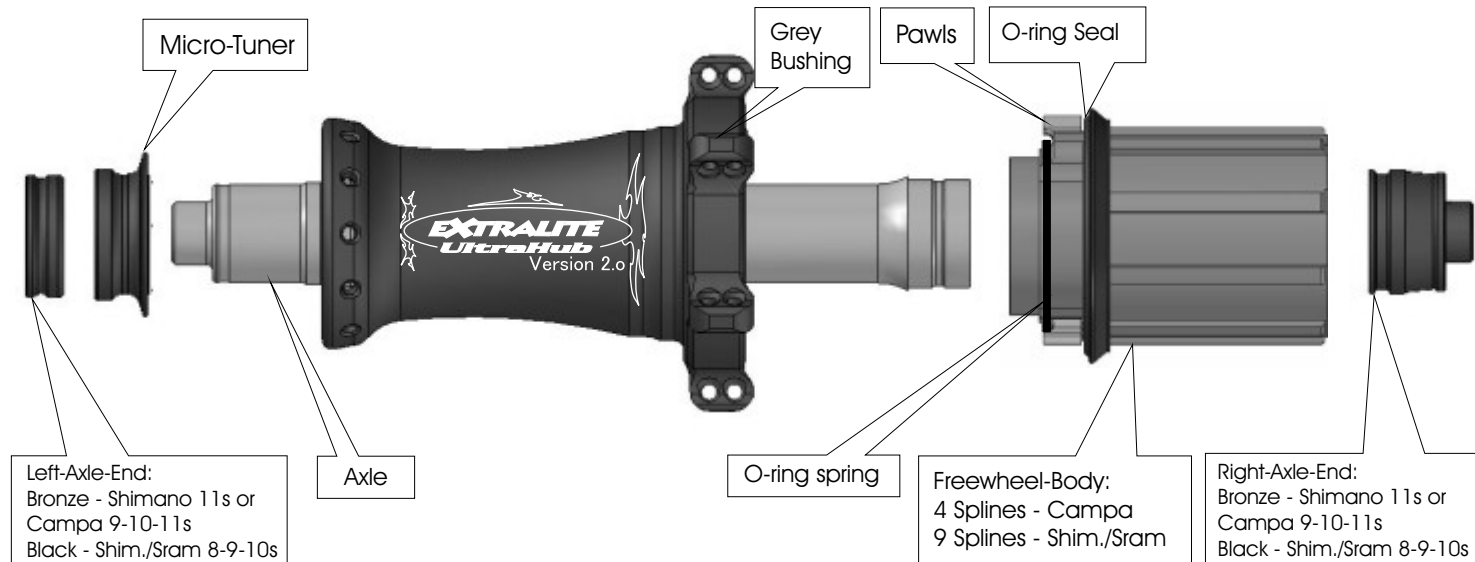

Left-Axle-End:
Bronze - Shimano 11s or
Campa 9-10-11s
Black - Shim./Sram 8-9-10s

Axle

O-ring spring

Freewheel-Body:
4 Splines - Campa
9 Splines - Shim./Sram

Right-Axle-End:
Bronze - Shimano 11s or
Campa 9-10-11s
Black - Shim./Sram 8-9-10s

REAR HUB MAINTENANCE (LEVEL 1)

Clean hubs externally with warm water and soap.
Never use high-pressure spray washing directly on hubs.

Cleaning Micro-Tuner area.

- 1) Pull Left-Axle-End and remove it. Fully unscrew Micro-Tuner by hand.
- 2) Clean all parts (Do not use aggressive solvents).
- 3) Grease Micro-Tuner thread.
- 4) Fully screw in Micro-Tuner by hand (check the thin threads engage correctly).
- 5) Insert left-axle-end.
- 6) Repeat preload tuning.

Note: once Micro-Tuner is removed the axle can be extracted from the right side.

This brings to a more complex operation, see more details on our website, "Tips & Manual" area.

Warning: you may find thin transparent plastic washers positioned between central bearing and central stopper on axle.

Handle washers carefully and remind to re-install them properly. Washer thickness tunes lip-seal preload and friction. Each hub unit receives a complete and optimal tolerance matching at the factory.

See more details on our website, "Tips & Manual" area.

Cleaning freewheel area.

- 1) Insert a 5mm hex wrench into left side of the axle.
- 2) Unscrew Right-Axle-End with a 5mm hex wrench.
- 3) Pull Freewheel-Body and remove it.
- 4) Clean all parts (do not use aggressive solvents).

Lubrication and reassembly

- 1) Grease freewheel area with 2cc. of very soft density grease as original Alugrease Super1.
- 2) Inserting Freewheel body: check the O-r spring and pawls correctly positioned, carefully press pawls one by one and insert freewheel partially. Check pawls engage ratchet wheel properly, insert completely.

- 3) Grese threads and tighten Right-Axle-End at 8-9 Nm.

Warning: Use only very soft density grease,

Medium or hard density grease may cause un-complete pawl engagement and this will seriously damage freewheel mechanism. Chemical additives may affect phisical properties of Lip-Seal, O-ring spring and Bushings.

Left spoke replacement.

- 1) Pull Left-Axle-End and remove it. Fully unscrew Micro-Tuner by hand.
- 2) The axle can be extracted from the right side just enough to replace damaged spoke. Warning: you may find thin transparent plastic washers positioned between central bearing and central stopper on axle.

UltraFront SPM



WARNING:

- 1) **Micro-Tuner must be on left side of the bicycle.**
- 2) Incorrect bearing preload may seriously damage bearings/parts and decreases performance.
- 3) Radial lacing: allowed on internal flange side only.
Destination: Road use only.

SPOKE TENSION:

Never exceed rim manufacturer recommended maximum tension.

Maximum spoke tension: 80Kgf +/- 10Kgf.

BEARING SET-UP

Bearings come pre-adjusted from the factory. Optimal preload is important for long bearing life.

Preload checking

Before modifying bearing preload carefully check the complete wheel as follows:

- 1) Install the complete wheel into dropouts and normally lock skewer.
- 2) Check there is no play at rim diameter.
- 3) Leave wheel free to completely stop spinning and carefully control latest instants of movement. Stopping should be very smooth.

Preload tuning

If necessary fine tune as follows; no tools are required.

- 1) Hold right axle end with one hand and turn Micro-Tuner fully clockwise by hand.
- 2) Unscrew Micro-Tuner for 1/8 to 1/4 of turn. You can snap out Left-Axle-End to enable operation.
- 3) Repeat preload checking and eventually slightly correct it. Turn anti-clockwise to increase rolling and stopping smoothness. Turn clockwise to correct play.

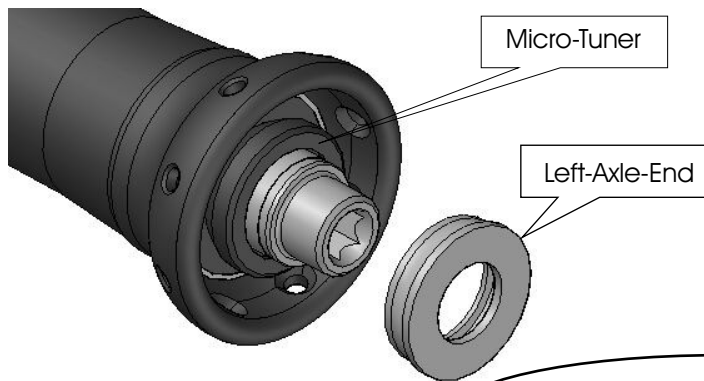

FRONT HUB MAINTENANCE (LEVEL 1)

Clean hubs externally with warm water and soap. Never use high-pressure spray washing directly on bearings.

Cleaning Micro-Tuner area.

Periodically clean Micro-Tuner area.

- 1) Pull Left-Axle-End and remove it. Fully unscrew Micro-Tuner by hand.
- 2) Clean all parts (Do not use aggressive solvents).
- 3) Grease Micro-Tuner thread.
- 4) Fully screw in Micro-Tuner by hand (check the thin threads engage correctly).
- 5) Pop in left-axle-end.
- 6) Repeat preload tuning.

Spoke replacement.

Right spoke:

- 1) Insert two 5mm hex wrench into both axle-ends and unscrew Right-Axle-End.
- 2) Replace damaged spoke.
- 3) Reassemble all parts. (Right-Axle-End: 10Nm)
- 4) Repeat preload tuning.

Left spoke:

- 1) Pull Left-Axle-End and remove it. Fully unscrew Micro-Tuner by hand.
- 2) Pop out Axle and right bearing pushing left side of the Axle with plastic mallet.
- 3) Replace damaged spoke.
- 4A) If you have "Pro Tool Kit" use its specific tools and procedure for reassembling.
- 4B) Pop in Axle and right bearing pushing right side of the Axle with plastic mallet.
- 5) Grease Micro-Tuner thread.
- 6) Fully screw in Micro-Tuner by hand (check the thin threads engage correctly).
- 7) Pop in Left-Axle-End.
- 8) Repeat preload tuning.

EXTRALITE

Extralite Limited Warranty

Extralite products are warranted against defects in materials and/or workmanship for a period of two years from original date of purchase to the original owner only.

Any Extralite product that is returned and found by Studio Riva to be defective in materials and/or workmanship will be repaired or replaced at the sole discretion of Studio Riva. This warranty is the sole and exclusive remedy. Studio Riva shall not be held liable for any indirect, special or consequential damages. The warranty is expressly limited to repair or replacement of the product that has been returned and found to be defective by Studio Riva and are the sole remedy of the warranty. No credits or refunds will be issued.

The warranty does not cover: normal wear, tear and fatigue; damage or failure due to accident or collision. Improper assembling, poor maintenance, alterations or modifications, installation of parts not compatible with Extralite products void this warranty. Warranty does not cover damage arising from crash, abuse and/or misuse or any other circumstances in which the product had been subjected to forces or loads beyond its design.

Immediately replace the component after crash and violent shock, or after continuous heavy use.

Improper use, modification and/or part changing, including surface finishing, could irreparably damage the component.

All labor charges for warranty service are responsibility of the product owner.

INSTALLATION WARNING:

Extralite components are extremely performing and lightweight, crafted with very high quality, they request adequate installation and maintenance care. We strongly recommended that a professional bike shop install and service your Extralite components.

Improper assembly and/or adjustment may significantly compromise strength and durability of the component causing serious personal injury.

Carefully check proper tightening torque of every bolt. Always respect installation recommendations.

Extralite components are designed for a specific use X-Country or Road or Downhill, respect product specific destination.

Note: the rider assumes all the risks regarding use and installation of Extralite components.