

# UltraTerra

## FEATURES

Hubs: UltraFront SP, UltraRear SP.

Spokes: 28-28 black bladed double butted straight pull.

Rims: lightweight 22x24mm clincher rims.

Graphics: laser etched.

Destination: X-Country use, V-Brakes only.

## WARNING:

1) **Front wheel: Micro Tuner must be on left side of the bicycle.**

2) Incorrect bearing preload may seriously damage bearings/parts and decreases performance.

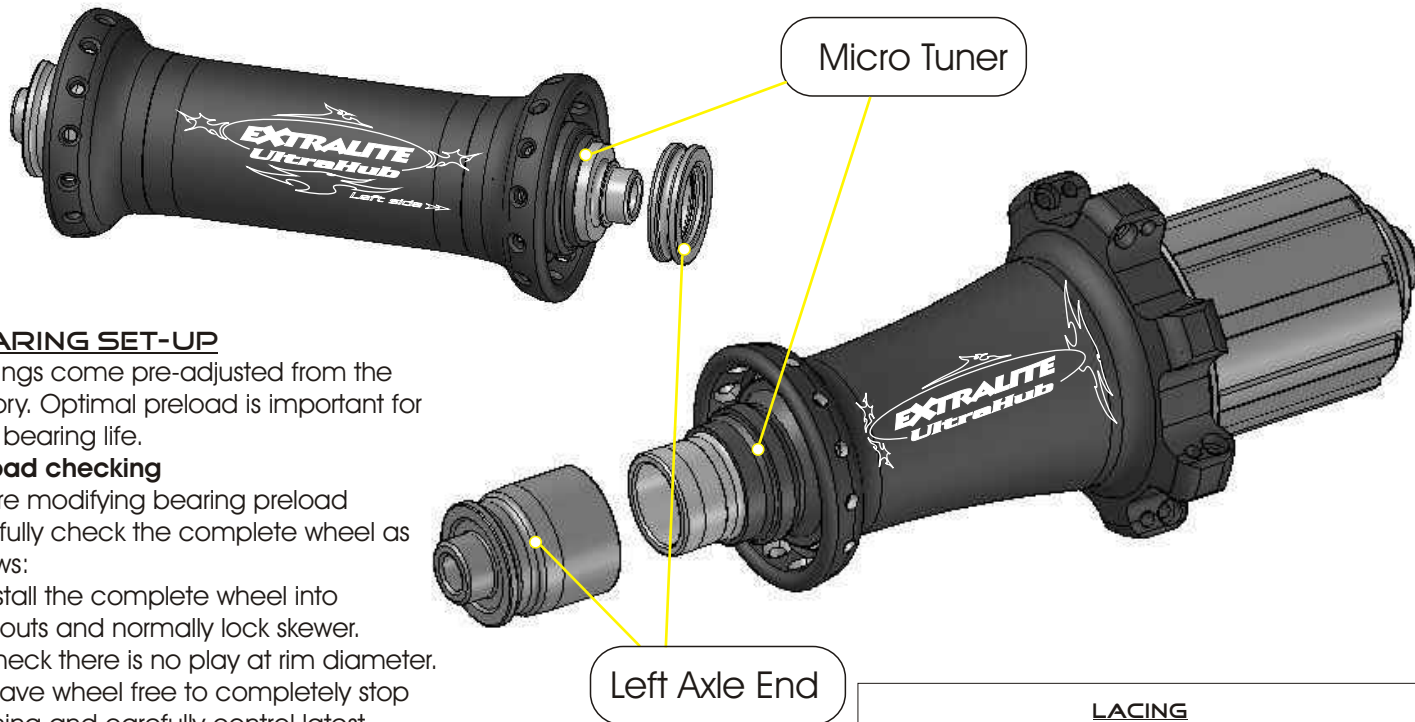

## BEARING SET-UP

Bearings come pre-adjusted from the factory. Optimal preload is important for long bearing life.

### Preload checking

Before modifying bearing preload carefully check the complete wheel as follows:

- 1) Install the complete wheel into dropouts and normally lock skewer.
- 2) Check there is no play at rim diameter.
- 3) Leave wheel free to completely stop spinning and carefully control latest instants of movement. Stopping should be very smooth.

### Preload tuning

If necessary fine tune as follows; no tools are required.

- 1) Hold right axle end with one hand and turn Micro-Tuner fully clockwise by hand.
- 2) Unscrew Micro-Tuner for 1/8 to 1/4 of turn. You can snap out Left Axle End to enable operation.
- 3) Repeat preload checking and eventually slightly correct it. Turn anti-clockwise to increase rolling and stopping smoothness. Turn clockwise to correct play.

## LACING

This wheels are carefully hand built using quality DB spokes and alloy nipples with hexagonal head. After the first few rides tension check and rim aligning might be required.

Always follow these rules to avoid damages to the alloy nipples:

- 1) Remove tyre, tube and/or flap.
- 2) Use only 5.5mm hex socket wrench to screw nipples.
- 3) Adjust nipples only from internal side of the rim (outer square tools should be only used for emergency)

Spare spoke/bearings sets are available at Extralite, please contact us for tech support.

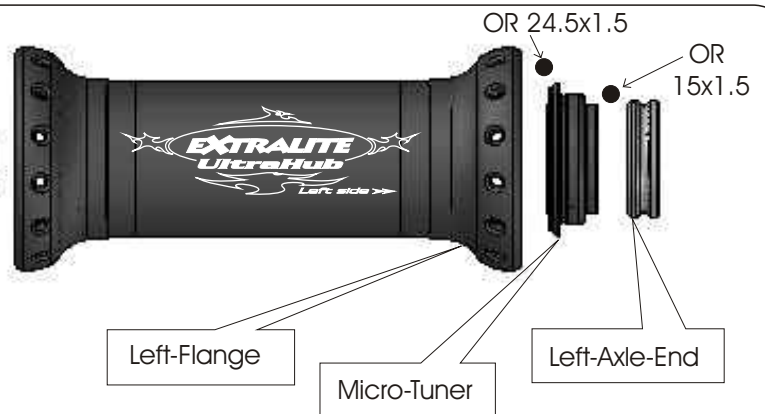
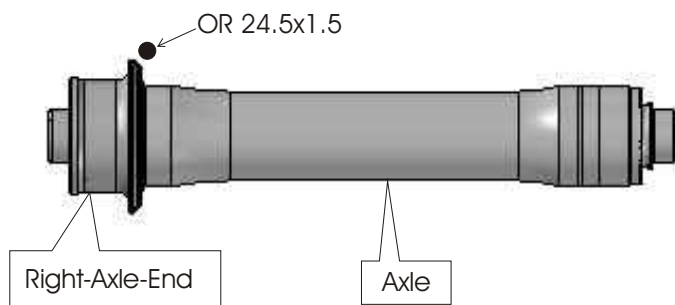

### FRONT HUB MAINTENANCE (LEVEL 1)

Clean hubs externally with warm water and soap.  
Never use high-pressure spray washing directly on bearings.

#### Micro-Tuner area.

Periodically clean Micro-Tuner area.

- 1) Pull Left-Axle-End and remove it. Fully unscrew Micro-Tuner by hand.
- 2) Pull out Front-Axle and clean all parts (Do not use aggressive solvents).
- 3) Grease Micro-Tuner thread.
- 4) Fully screw in Micro-Tuner by hand (check the thin threads engage correctly).
- 5) Pop in left-axle-end.
- 6) Put External-OR 15x1.5 between Micro-Tuner and Left-Axle-End.  
Put External-OR 24.5x1.5 between Micro-Tuner and Left-Flange.  
Put External-OR 24.5x1.5 between Micro-Tuner and Right-Axle-End.
- To decrease rolling resistance oil 24.5x1.5 External-OR.
- 7) Repeat preload tuning.

#### Spoke replacement.

- 1) Pull Left-Axle-End and remove it. Fully unscrew Micro-Tuner by hand.
- 2) Pop out Axle by pushing left side of the Axle.
- 3) Replace damaged spoke.
- 4) Pop in Axle pushing right side of the Axle.
- 5) Grease Micro-Tuner thread.
- 6) Fully screw in Micro-Tuner by hand (check the thin threads engage correctly).
- 7) Pop in Left-Axle-End.
- 8) Put External-OR 15x1.5 between Micro-Tuner and Left-Axle-End.  
Put External-OR 24.5x1.5 between Micro-Tuner and Left-Flange.  
Put External-OR 24.5x1.5 between Micro-Tuner and Right-Axle-End.
- To decrease rolling resistance oil 24.5x1.5 External-OR.
- 9) Repeat preload tuning.

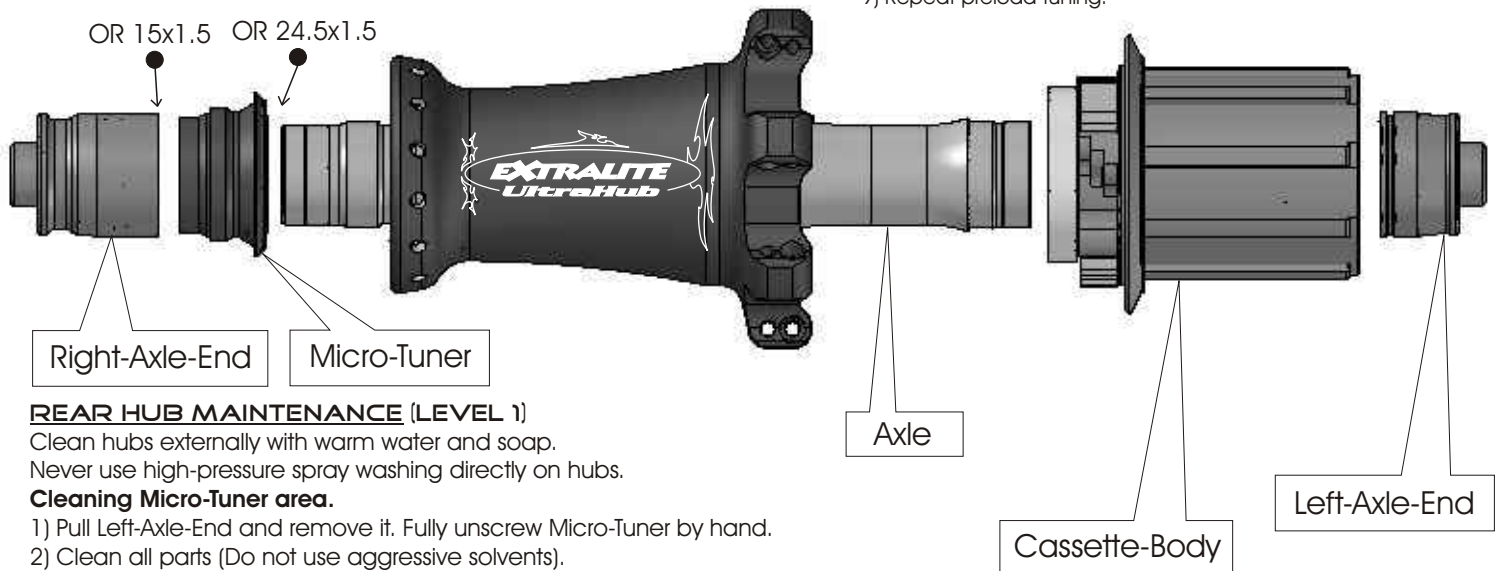

### REAR HUB MAINTENANCE (LEVEL 1)

Clean hubs externally with warm water and soap.  
Never use high-pressure spray washing directly on hubs.

#### Cleaning Micro-Tuner area.

- 1) Pull Left-Axle-End and remove it. Fully unscrew Micro-Tuner by hand.
- 2) Clean all parts (Do not use aggressive solvents).
- 3) Grease Micro-Tuner thread.
- 4) Fully screw in Micro-Tuner by hand (check the thin threads engage correctly).
- 5) Insert left-axle-end.  
Put External-OR 15x1.5 between Micro-Tuner and Left-Axle-End.  
Put External-OR 24.5x1.5 between Micro-Tuner and Left-Flange.
- To decrease rolling resistance oil 24.5x1.5 External-OR.
- 6) Repeat preload tuning.

#### Cleaning freewheel area.

- 1) Remove Left-Axle-End pulling it by hand and insert a 10mm hex wrench into left axle side.
- 2) Unscrew Right-Axle-End with a 5mm hex wrench.
- 3) Pull Cassette-Body and remove it.
- 4) Clean all parts (do not use aggressive solvents).

#### Lubrication and reassembly

- 1) Grease freewheel area with 2cc. of soft grease or W90 gearbox oil.
- 2) Inserting cassette body: check for correct spring/pawl positioning, carefully press pawls one by one and insert partially. Check pawls engagement, insert completely.
- 3) Tighten Right-Axle-End at 4-5 Nm.
- 4) Pop-in Left-Axle-End and reinstall all external OR.

#### Left spoke replacement.

- 1) Pull Left-Axle-End and remove it. Fully unscrew Micro-Tuner by hand.
- 2) Pull Cassette-Body and extract Axle from hub Body.
- 3) Replace damaged spoke.
- 4) Grease freewheel area with 2cc. of soft grease or W90 gearbox oil.
- 5) Inserting Cassette-Body: check for correct spring/pawl positioning, carefully press pawls one by one and insert partially. Check pawls engagement, insert completely.
- 6) Grease Micro-Tuner thread.
- 7) Fully screw in Micro-Tuner by hand (check the thin threads engage correctly).
- 8) Pop in Left-Axle-End.
- 9) External-OR 15x1.5 should be positioned between Micro-Tuner and Left-Axle-End.  
Put External-OR 24.5x1.5 between Micro-Tuner and Left-Flange.
- 10) Repeat preload tuning.