

DESTINATION

Road or Cyclo-cross use. Fork width: 100mm, thru axle 12mm or quick release. Centerlock rotors.

GUIDELINE

Never use high-pressure spray washing directly onto the hub. Clean hubs externally with warm water and soap.

Periodically clean hub internals (every 6-12 months in normal and dry conditions, every 3 months in wet conditions and always before leaving the wheel un-used for more than 1 month) see Level1 instructions.

Warning: Water and moisture stagnant inside hub can permanently damage bearings.

FRONT HUB MAINTENANCE (LEVEL 1)

Clean hubs externally with warm water and soap.

Never use high-pressure spray washing directly on bearings.

axle Assembly removal.

Periodically clean hub internals to avoid water and moisture stagnant inside hub.

- 1) Pull and extract Right Axle End.
- 2) Push and extract the Axle from right side.
- 3) Clean all parts.
- 4) Grease bearing contact area on Axle and Right Axle End and Micro Tuner internal faces.
- 4) Reassemble all parts.
- 5) Repeat bearing set-up preload tuning.

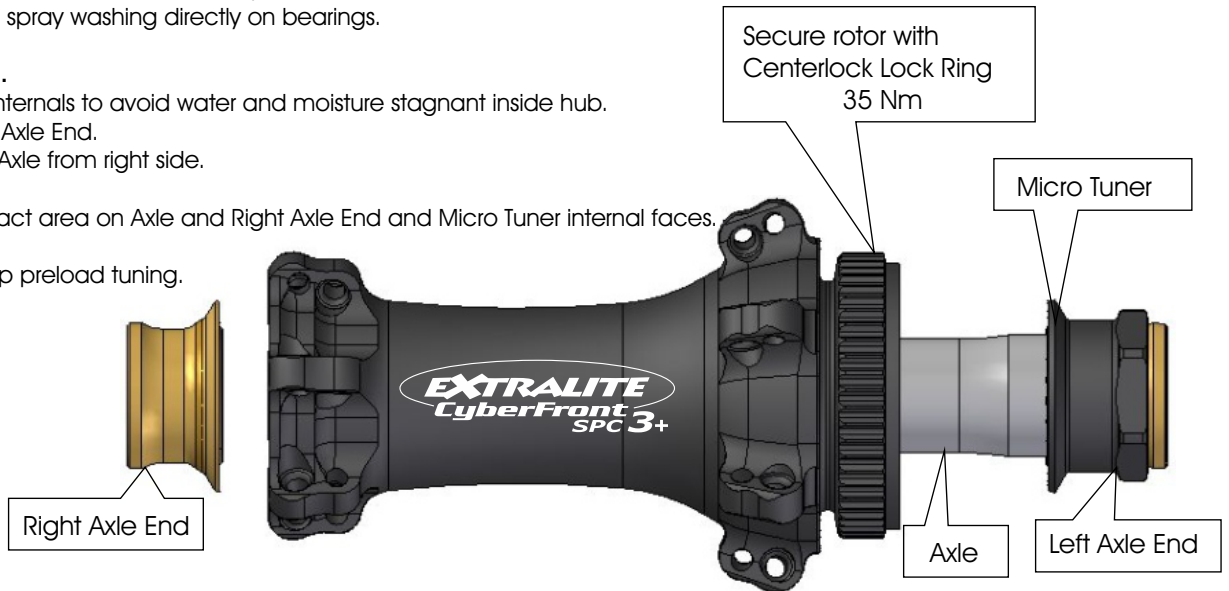

BEARING SET-UP

Bearings come pre-adjusted from the factory. Optimal preload is important for long bearing life.

Preload checking

Before modifying bearing preload carefully check the complete wheel as follows:

- 1) Install the complete wheel into dropouts and normally lock skewer.
- 2) Check there is no play at rim diameter.
- 3) Leave wheel free to completely stop spinning and carefully control latest instants of movement. Stopping should be very smooth.

Preload tuning

If necessary fine tune as follows.

- 1) Install wheel into dropouts and normally lock skewer, gently turn Micro-Tuner fully clockwise with a 19mm wrench.
- 2) Unscrew Micro Tuner for 1/8 to 1/4 of turn.
- 3) Repeat preload checking and eventually slightly correct it. Turn anti-clockwise to increase rolling and stopping smoothness. Turn clockwise to correct play. The optimal bearing preload cancels play at the rim without affecting rolling smoothness.

Wheelbuilder's manual

DIMENSION FOR WHEEL BUILDING

Right side spoke hole \varnothing : 2.8mm rounded
Right flange drilling \varnothing : 30mm
Center to right flange: 33mm
Center to left flange: 25mm
Disc side spoke hole \varnothing : 2.8mm rounded
Disc flange drilling \varnothing : 47mm

LACING

See www.extralite.com to find pre-calculated spoke lengths.
Respect 24h lacing pattern (see drawing).
Do not laterally over-push Axle at the spoke stretching procedure. Excessive lateral load may damage external bearings.

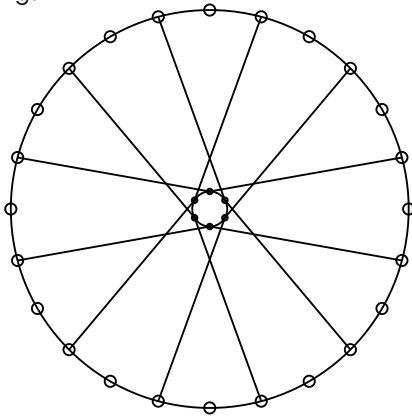

24H Lacing Pattern

SPOKE TENSION

Hub maximum spoke tension:

Disc Side: 120Kgf

Right Side: consequently

Reduce tension if the rim manufacturer recommends a lower value.

COMPATIBILITY

Compatible with Berd spokes (without tangential washers), steel and carbon spokes (2.7mm max width).

CyberFront SPC 3+ hub dimensions

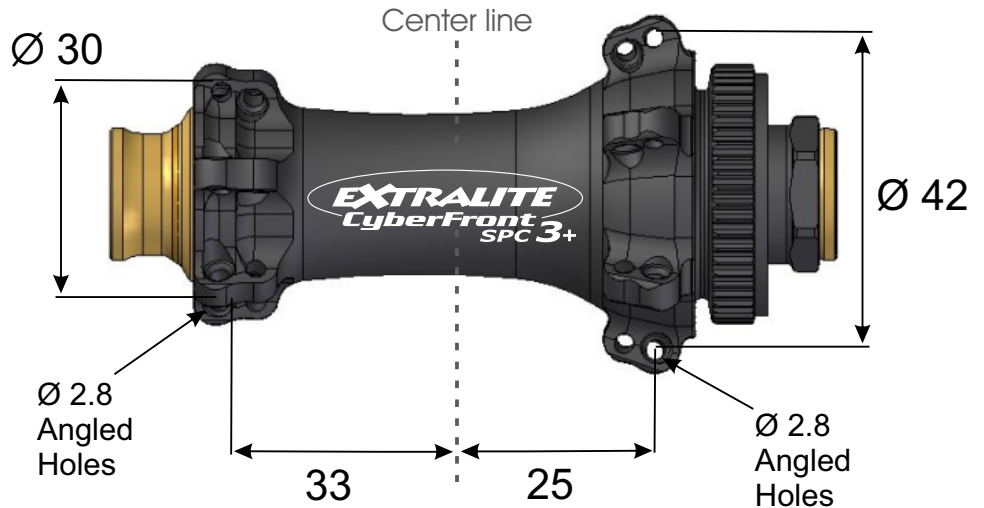

Extralite Limited Warranty

Extralite products are warranted against defects in materials and/or workmanship for a period of two years from original date of purchase to the original owner only.

Any Extralite product that is returned and found by Studio Riva to be defective in materials and/or workmanship will be repaired or replaced at the sole discretion of Studio Riva. This warranty is the sole and exclusive remedy. Studio Riva shall not be held liable for any indirect, special or consequential damages. The warranty is expressly limited to repair or replacement of the product that has been returned and found to be defective by Studio Riva and are the sole remedy of the warranty. No credits or refunds will be issued.

The warranty does not cover: normal wear, tear and fatigue; damage or failure due to accident or collision. Improper assembling, poor maintenance, alterations or modifications, installation of parts not compatible with Extralite products void this warranty. Warranty does not cover damage arising from crash, abuse and/or misuse or any other circumstances in which the product had been subjected to forces or loads beyond its design. Immediately replace the component after crash and violent shock, or after continuous heavy use. Improper use, modification and/or part changing, including surface finishing, could irreparably damage the component. All labor charges for warranty service are responsibility of the product owner.

INSTALLATION WARNING: Extralite components are extremely performing and lightweight, crafted with very high quality, they request adequate installation and maintenance care. We strongly recommended that a professional bike shop install and service your Extralite components. Improper assembly and/or adjustment may significantly compromise strength and durability of the component causing serious personal injury. Carefully check proper tightening torque of every bolt. Always respect installation recommendations. Extralite components are designed for a specific use X-Country or Road or Downhill, respect product specific destination. Note: the rider assumes all the risks regarding use and installation of Extralite components.