

CyberRear SP-2B

Owner's manual

DESTINATION Brompton folding bike, 112mm wide.

GUIDELINE Never use high-pressure spray washing directly onto the hub. Clean hubs externally with warm water and soap. Periodically clean hub internals (every 12 months in normal and dry conditions, every 6 months in wet conditions and always before leaving the wheel un-used for more than 1 month) see Level1 instructions.

Warning: Water and moisture stagnant inside hub can permanently damage bearings.

Warning: Use only very soft density pure grease as original Alugrease Super1, medium or hard density grease may cause un-complete pawl engagement and this will seriously damage freewheel mechanism. Most greases contain chemical additives that may damage OR Seals and, most of all, can break the freewheel OR spring.

INSTALLATION

Install Cog Lock Ring at a maximum torque of 25-30Nm.

CyberRear SP-2B features the special B-Lock system to secure the wheel to the frame saving the weight of the Quick release. You can install B-Lock Bolts with or without washer between bolt heads and frame dropouts, tight at 12Nm



BEARING PRELOAD SET-UP:

Optimal bearing preload is important for a long bearing life.

Micro Tuner comes pre-adjusted from the factory. Do not modify its position if not necessary.

Checking

Before modifying bearing preload carefully check the complete wheel as follows:

- 1) Install wheel into dropouts and normally lock skewer.
- 2) Check there is no play at rim diameter.
- 3) Leave wheel free to completely stop spinning and carefully control latest instants of movement. Stopping should be very smooth.

Preload Tuning

If necessary fine tune as follows.

- 1) Install wheel into dropouts and normally lock skewer.
- 2) If you feel play at the rim turn in Micro Tuner (clockwise). Use a 20mm wrench, very delicate torque and manners.
- 3) Unscrew Micro Tuner for ca 1/4 of turn to release excessive preload on bearing balls and achieve max rolling smoothness.
- 4) Repeat Preload Checking and eventually slightly correct it.
- 5) The optimal bearing preload cancels play at the rim without affecting rolling smoothness.

Warning Incorrect bearing preload can damage bearings and freewheel parts additionally decreases hub performance.

Extralite Limited Warranty

Extralite products are warranted against defects in materials and/or workmanship for a period of two years from original date of purchase to the original owner only.

Any Extralite product that is returned and found by Studio Riva to be defective in materials and/or workmanship will be repaired or replaced at the sole discretion of Studio Riva. This warranty is the sole and exclusive remedy. Studio Riva shall not be held liable for any indirect, special or consequential damages. The warranty is expressly limited to repair or replacement of the product that has been returned and found to be defective by Studio Riva and are the sole remedy of the warranty.

No credits or refunds will be issued.

The warranty does not cover: normal wear, tear and fatigue; damage or failure due to accident or collision. Improper assembling, poor maintenance, alterations or modifications, installation of parts not compatible with Extralite products void this warranty. Warranty does not cover damage arising from crash, abuse and/or misuse or any other circumstances in which the product had been subjected to forces or loads beyond its design. Immediately replace the component after crash and violent shock, or after continuous heavy use. Improper use, modification and/or part changing, including surface finishing, could irreparably damage the component.

All labor charges for warranty service are responsibility of the product owner.

INSTALLATION WARNING: Extralite components are extremely performing and lightweight, crafted with very high quality, they request adequate installation and maintenance care. We strongly recommended that a professional bike shop install and service your Extralite components. Improper assembly and/or adjustment may significantly compromise strength and durability of the component causing serious personal injury. Carefully check proper tightening torque of every bolt. Always respect installation recommendations. Extralite components are designed for a specific use X-Country or Road or Downhill, respect product specific destinations.

Note: the rider assumes all the risks regarding use and installation of Extralite components.

DISASSEMBLY FOR CLEANING. MAINTENANCE (LEVEL 1).

- 1) Remove Tensioner and B-Lock Bolts
- 2) Extract Left Axle End by pulling it by hands.
- 3) Hold Right Axle End with a 17mm closed hex wrench and fully unscrew and extract Micro Tuner (use a 20mm wrench).
- 4) Hold Axle with a 14mm closed hex wrench and unscrew Right Axle End.
- 5) Pull Freewheel Body and remove it.
- 6) Extract Axle by pulling it from right side.
- 7) Clean all parts.

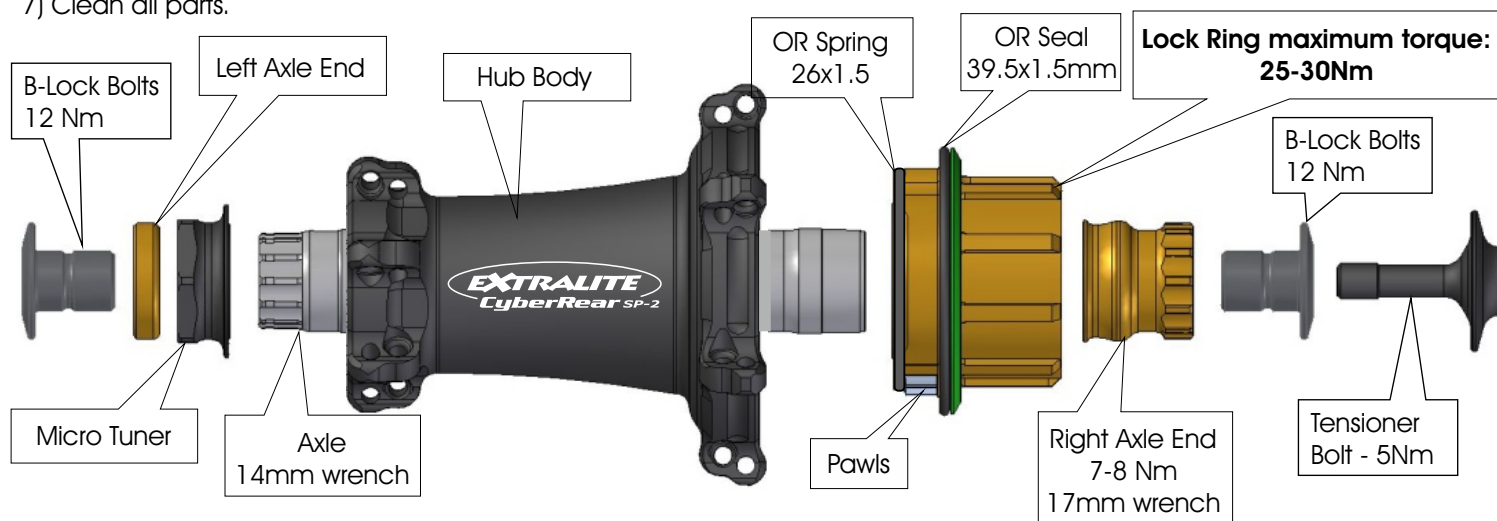

Lubrication and reassembly

- 1) Slightly grease bearing contact surfaces on Axle.
- 2) Insert Axle from right side gently pushing it with a plastic mallet.
- 3) Temporary screw in Micro Tuner for 2to3 turns only. **Avoid full turning to prevent damages.**
- 4) Grease freewheel area with 2cc. of very soft density grease as original Alugrease Super1. Never use Lithium, additivated grease nor thick grease
- 5) Oil OR-Seal with thin oil. Oils that are thicker than W40 engine oil may increase freewheel resistance.
- 6) Inserting Freewheel body: check the OR seal, OR Spring and Pawls are correctly positioned, carefully press pawls one by one and partially insert freewheel. Check that pawls engage ratchet wheel properly then insert completely. **Do not pinch seal OR**
- 7) Grease threads and tighten Right Axle End at 7-8 Nm.
- 8) Gently push Axle from right side using a plastic mallet.
- 9) Gently fully screw in Micro Tuner and unscrew it for 1/4 to 1/2 of turn to release excessive preload on bearing balls.
- 10) Set-up bearing preload with preload tuning, see chapter.

Wheelbuilder's manual

DIMENSION FOR WHEEL BUILDING

- Spoke hole \varnothing : 2.8mm
- Right flange drilling \varnothing : 52mm (3mm head to head)
- Left flange drilling \varnothing : 32mm (3mm head to head)
- Center to right flange: 22mm
- Center to left flange: 29mm
- Frame width: 112mm

LACING

- See www.extralite.com to find pre-calculated spoke lengths.
- Make sure hub is properly assembled and adjusted before lacing.
- Respect specific lacing pattern.

Hub maximum spoke tension:

Drive Side: 130 Kgf

Left Side: consequently

Reduce tension if the rim manufacturer recommends a lower value.

Do not laterally over-push Axle at the spoke stretching procedure.
Excessive lateral load may damage external bearings.

