

CyberRear SPC 3+

Owner's manual

DESTINATION

Road or Cyclo-cross use. Frame width: 142mm (Thru axle 12mm) or 135(Quick release). Centerlock rotors.

GUIDELINE

Install Cog Lock Ring at a maximum torque of 25-30Nm.

Never use high-pressure spray washing directly onto the hub. Clean hubs externally with warm water and soap.

Periodically clean hub internals (every 6-12 months in normal and dry conditions, every 3 months in wet conditions and always before leaving the wheel un-used for more than 1 month) see Level1 instructions.

Warning: Water and moisture stagnant inside hub can permanently damage bearings.

Warning: Use only very soft density pure grease as original Alugrease Super1, medium or hard density grease may cause un-complete pawl engagement and this will seriously damage freewheel mechanism. Most greases contain chemical additives that may damage OR Seals and, most of all, can break the freewheel OR spring.

Warning: CyberRear mechanisms are suitable for road and cyclocross use (and not MTB), **shortest gear ratio 1.00**. Shorter ratios may result in high torque and damage freewheel mechanism.

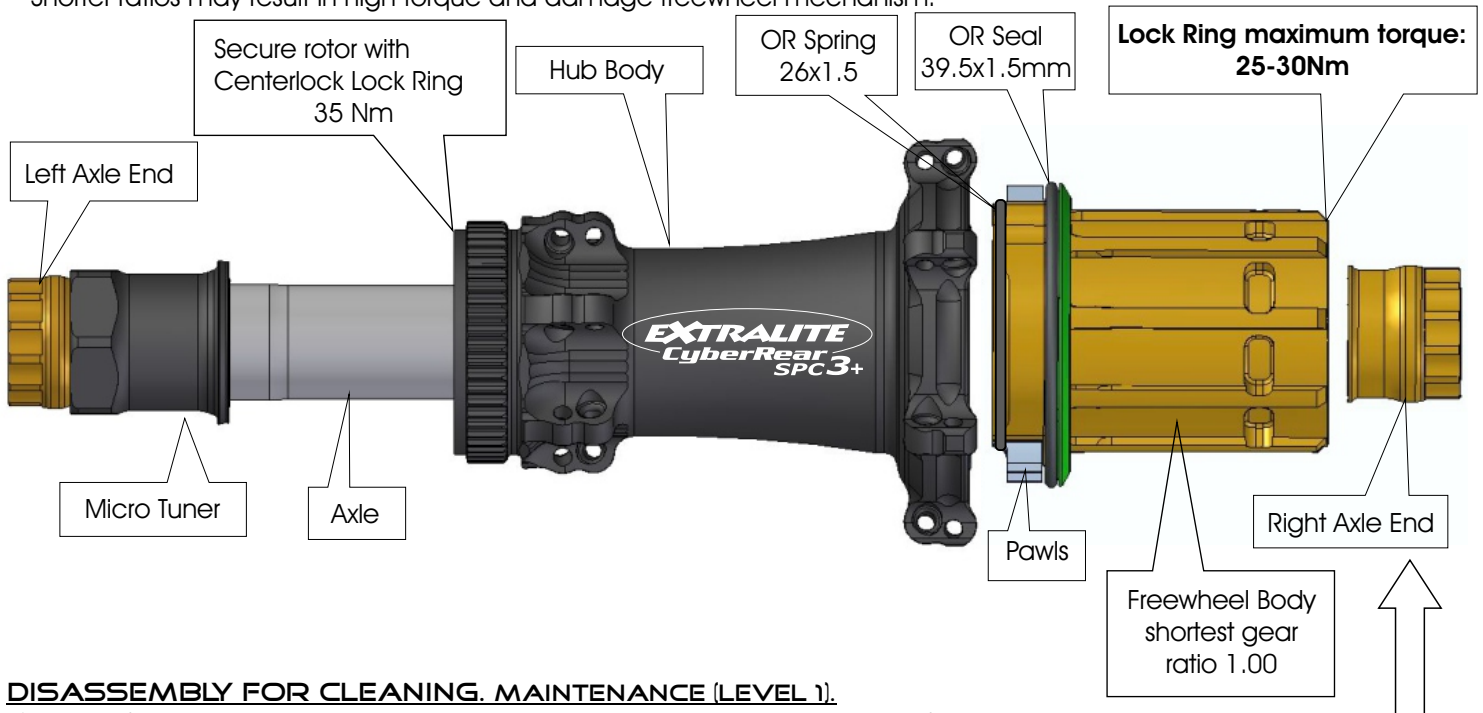

DISASSEMBLY FOR CLEANING. MAINTENANCE (LEVEL 1).

- 1) Hold Left Axle End with a 17mm closed wrench for 142mm (5mm hex wrench for 135mm Quick Release) .
- 2) Unscrew and remove Right Axle End.
- 3) Pull Freewheel Body and remove it.
- 4) Extract Axle by pushing it from right side.
- 5) Clean all parts (do not use aggressive solvents).

Wear check

We recommend to replace freewheel assembly after 40.000 km (25.000 miles).

This mileage may vary by several factors like maintenance frequency, environmental contamination, rider power output, etc.

After all parts are cleaned check that pawls seat are not wearred and still square.

Lubrification and reassembly

- 1) Slightly grease bearing contact surfaces on Axle.
- 2) Insert Axle from left side gently pushing it with a plastic mallet.
- 3) Temporary unscrew out Micro Tuner for 1to2 turns. **Avoid screwing it to prevent damages.**
- 4) Grease freewheel area with 2cc. of very soft density grease as original Alugrease Super1. Never use Lithium, additivated nor thick grease
- 5) Oil OR-Seal with thin oil. Oils that are thicker than W40 engine oil may increase freewheel resistance.
- 6) Inserting Freewheel body: check the OR seal, OR Spring and Pawls are correctly positioned, carefully press pawls one by one and partially insert freewheel. Check that pawls engage ratchet wheel properly then insert completely. **Do not pinch seal OR**
- 7) Grease threads and tighten Right Axle End at 7-8 Nm.
- 8) Gently push Axle from right side using a plastic mallet.
- 9) Gently fully screw in Micro Tuner and unscrew it for 1/4 to 1/2 of turn to release excessive preload on bearing balls.
- 10) Set-up bearing preload with preload tuning, see next page.

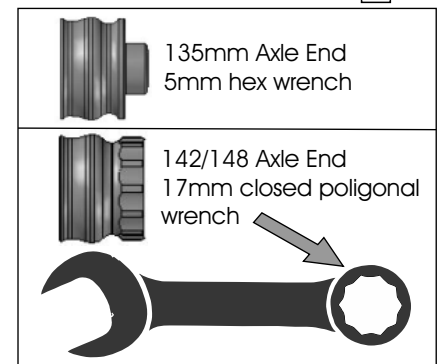

BEARING PRELOAD SET-UP:

Optimal bearing preload is important for a long bearing life.

Micro Tuner comes pre-adjusted from the factory. Do not modify its position if not necessary.

Checking

Before modifying bearing preload carefully check the complete wheel as follows:

- 1) Gently push Axle from right side using a plastic mallet.
- 2) Install wheel into dropouts and normally lock skewer.
- 3) Check there is no play at rim diameter.
- 4) Leave wheel free to completely stop spinning and carefully control latest instants of movement. Stopping should be very smooth.

Preload Tuning

If necessary fine tune as follows.

- 1) Gently push Axle from right side using a plastic mallet.
- 2) Install wheel into dropouts and normally lock skewer.
- 3) If you feel play at the rim turn in Micro Tuner (clockwise). Use a 21mm wrench, very delicate torque and manners.
- 4) Unscrew Micro Tuner for ca 1/4 of turn to release excessive preload on bearing balls and achieve max rolling smoothness.
- 5) Repeat Preload Checking and eventually slightly correct it.
- 6) The optimal bearing preload cancels play at the rim without affecting rolling smoothness.

Warning Incorrect bearing preload can damage bearings and freewheel parts additionally decreases hub performance.

Wheelbuilder's manual

DIMENSION FOR WHEEL BUILDING

Spoke hole Ø: 2.8mm rounded

Disc flange drilling Ø: 33mm

Center to left flange: 35mm

Center to right flange: 20mm

Right flange drilling Ø: 52mm

Frame width: 142mm (Thru axle 12mm) or 135(Quick release)

COMPATIBILITY

Compatible with Berd spokes (without tangential washers), steel and carbon spokes (2.7mm max width).

LACING

Respect 24h lacing pattern (see drawing).

See www.extralite.com to find pre-calculated spoke lengths.

Make sure hub is properly assembled and adjusted before lacing.

Hub maximum spoke tension:

Drive Side: 130 Kgf

Left Side: consequently

In any case never exceed the maximum tension recommended by rim manufacturer.

Do not laterally over-push Axle at the spoke stretching procedure. Excessive lateral load may damage external bearings.

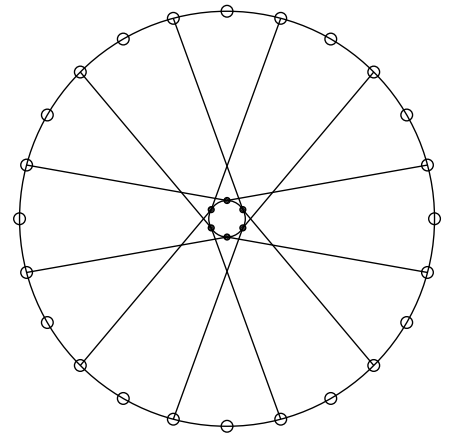

24H Lacing Pattern

CyberRear SPC 3+ hub dimensions

