

# Hyper V3F

## Owner's manual

info@extralite.com

### DESTINATION

X-Country, Enduro.

### GUIDELINE

Never use high-pressure spray washing directly onto the hub. Clean hubs externally with warm water and soap. Periodically clean hub internals (every 6-12 months in normal and dry conditions, every 3 months in wet conditions and always before leaving the wheel un-used for more than 1 month, see Level1 instructions).

**Warning:** Water and moisture stagnant inside hub can permanently damage bearings.



### BEARING SET-UP

Bearings come pre-adjusted from the factory. Optimal preload is important for long bearing life.

**Warning** Incorrect bearing preload decreases hub performance.

#### Preload checking

Before modifying bearing preload carefully check the complete wheel as follows:

- 1) Install the complete wheel into dropouts and normally lock skewer.
- 2) Check there is no play at rim diameter.
- 3) Leave wheel free to completely stop spinning and carefully control latest instants of movement. Stopping should be very smooth.

#### Preload tuning

If necessary fine tune as follows.

- 1) Install wheel into dropouts and normally lock skewer, gently turn Micro-Tuner fully clockwise with a 21mm wrench.
- 2) Unscrew Micro Tuner for 1/8 to 1/4 of turn.
- 3) Repeat preload checking and eventually slightly correct it. Turn anti-clockwise to increase rolling and stopping smoothness. Turn clockwise to correct play. The optimal bearing preload cancels play at the rim without affecting rolling smoothness.

## Lacing

See [www.extralite.com](http://www.extralite.com) to find pre-calculated spoke lengths.

Hubs are compatible with max 2.75mm spokes: Steel, Carbon and Berd (without tangential washer).

Respect specific lacing pattern (see drawing).

Do not laterally over-push Axle at the spoke stretching procedure. Excessive lateral load may damage external bearings.

### SPOKE TENSION:

**Hub maximum spoke tension: 90Kgf**

Reduce tension if the rim manufacturer recommends a lower value.

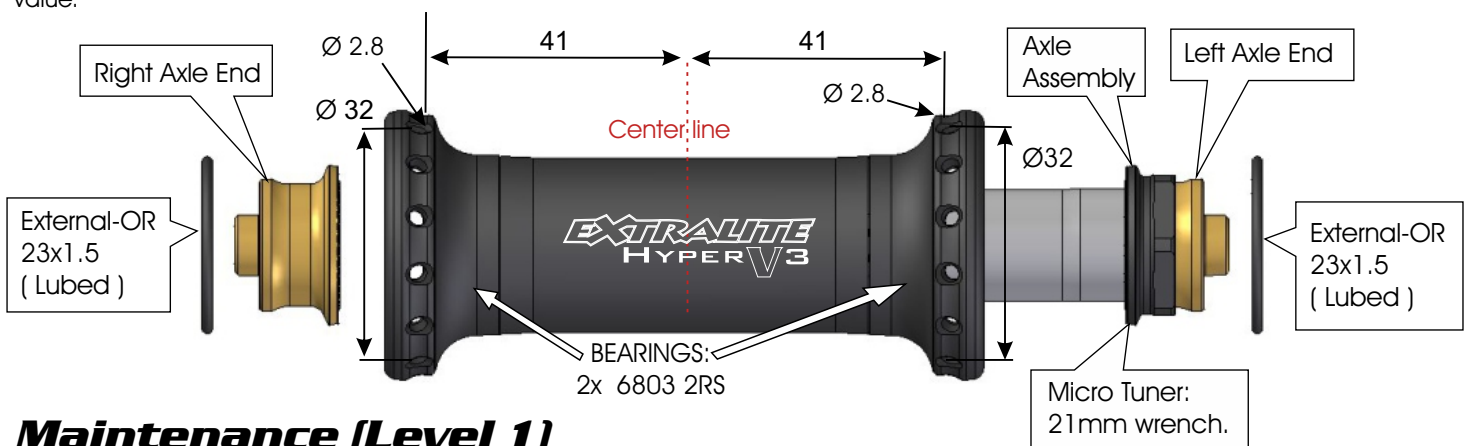

## Maintenance (Level 1)

Clean hubs externally with warm water and soap. Never use high-pressure spray washing directly on bearings.

Periodically clean hub internals to avoid water and moisture stagnant inside hub.

### Axle Assembly removal.

- 1) Pull and extract Right Axle End with External OR (23x1.5).
- 2) Push and Extract Axle Assembly and External OR (27x1.5) from right side.
- 3) Clean all parts.
- 4) Grease bearing contact area on Axle and Right Axle End and Micro Tuner internal faces.
- 5) Reassemble all parts.
- 6) Repeat bearing set-up preload tuning.
- 7) Oil and install both External Orings only when the hub is completely assembled and tuned.