

Hyper 2+ Freewheel Kit

Compatible with HyperBoost R, HyperRear2, HyperCamber2, Hyper JR, HyperVR
NOT Compatible with Version 1 and Version 3 HyperHubs

WARNING: Execute these operations only on a well clean and well illuminated table, you'll have to handle delicate internal parts and tiny springs, even small debris can compromise the freewheel engagement mechanism. Carefully follow maintenance instructions step by step. Schedule periodical cleaning and lubrication sessions; water and moisture stagnant inside hub will damage bearings in few weeks.

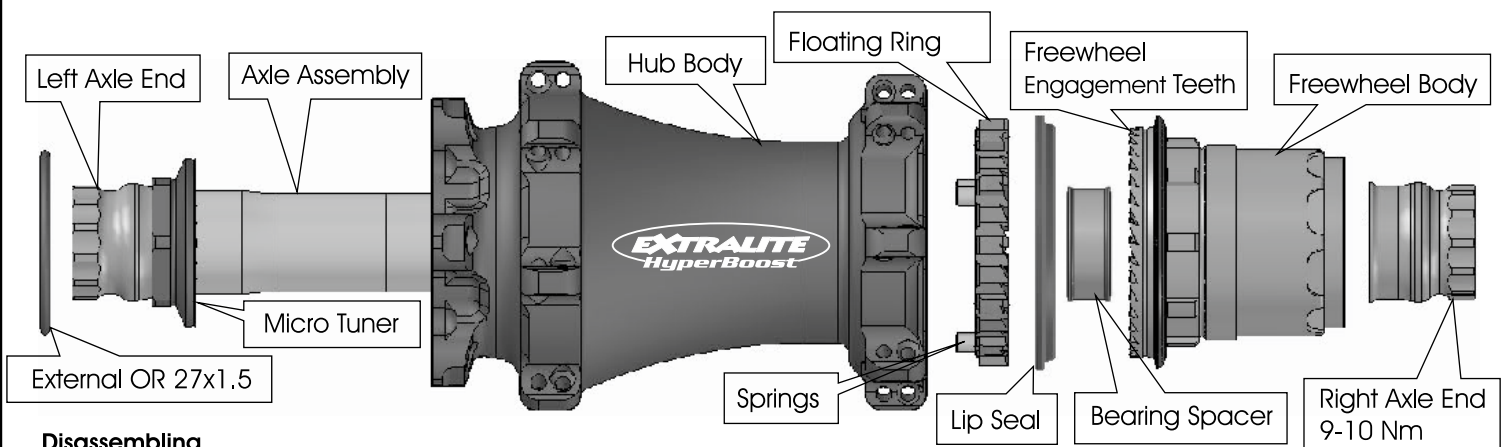

Disassembling

- 1) Hold Left Axle End with a 17mm closed wrench (5mm hex wrench for 135mm).
- 2) Unscrew Right Axle End with another 17mm closed wrench (5mm hex wrench for 135mm).
- 3) Pull Freewheel Body and remove it.
- 4) Extract Bearing Spacer.
- 5) Remove Lip Seal from Hub Body.
- 6) Remove Floating Ring from Hub Body, you'll find 3 tiny springs on its back side.
- 7) Push out Axle Assembly and completely extract it from disc side.

Cleaning

- 8) Clean all parts (Do not use aggressive solvents).
- 9) Clean very carefully all Internal Splines.

Warning: even one small debris can void freewheel engagement.

Warning: carefully check hubshell Splines (see below).

Hubshell Splines Check - IMPORTANT!

Clean and degrease perfectly hubshell internal splines, all of them.

Check with eye magnifier both the 2 rows of splines (12 + 12T) see image.

Once hub-shell internal is perfectly clean check well with eye magnifier both the 2 rows of splines (12 + 12T) see image. Every spline corners (clockwise corners) should be well square and flat.

Minimum conditions required

Install the Special Floating Ring on an hubshell with at least 12 very good splines (1 row).

In case your hub has 24 used splines and you are not sure about it contact us info@extralite.com providing clear close-up photo.

Potential risk

When riding HyperHubs with dirt inside the hard particles of sand can badly grind the hubshell splines. Shortly the sand wears the hub-shell splines till the "floating ring" will not move freely anymore. This easily causes an uncomplete freewheel engagement and damages permanently the newly installed freewheel parts. In this case replacing "floating ring" and/or "Freewheel body" does not solve. The expensive hub-shell should be replaced (or eventually sent back for re-sharpening).

For more detailed informations check HyperHubs Tips on www.extralite.com

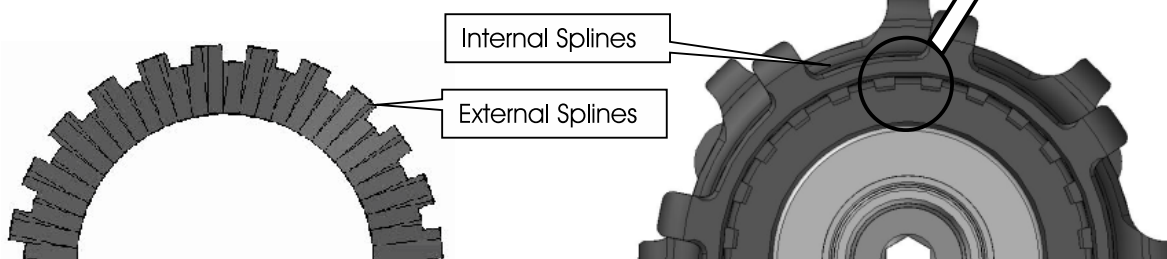
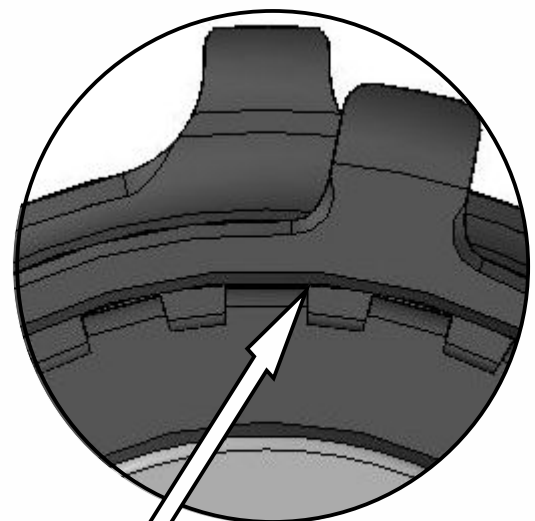
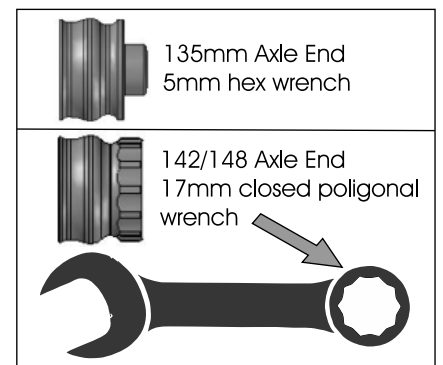

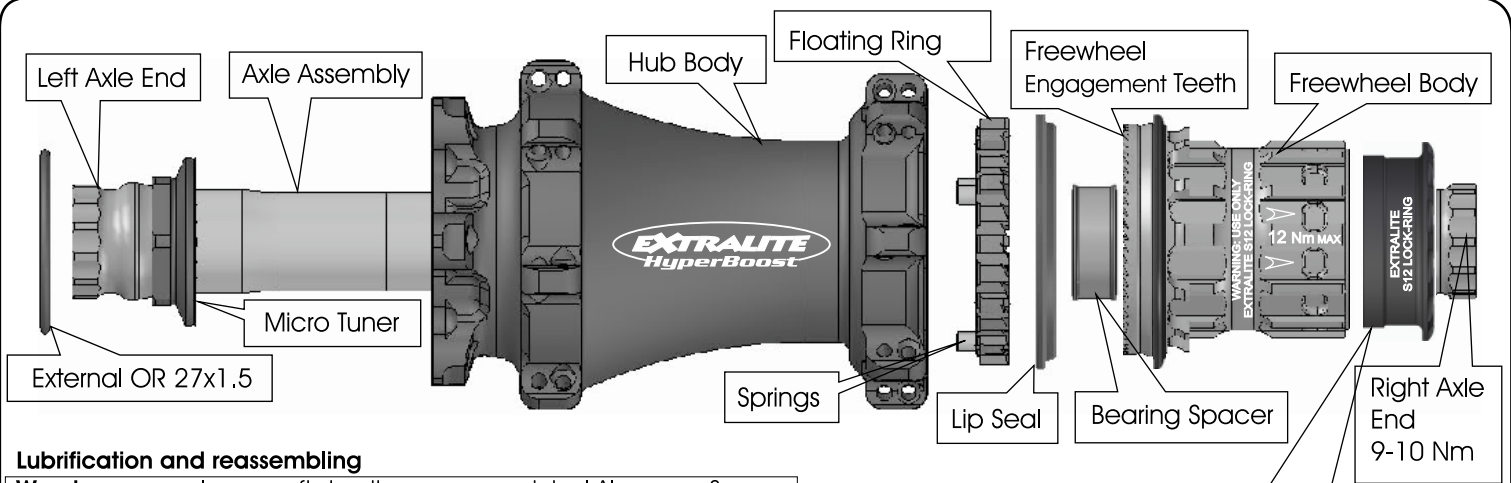

Lubrication and reassembling

Warning: use only very soft density grease as original Alugrease Super. Never use medium-dense or sticky grease since can slow down Floating Ring movement, this can destroy the freewheel mechanism! Chemical additives may damage O-rings and Lip Seal.

- 10) Grease Axle on bearing contact areas.
- 11) Fill up Micro Tuner internal face with soft grease.
- 12) Insert Axle Assembly from disc side.
- 13) Insert Bearing Spacer.
- 14) Oil Internal Splines of Hub Body with 1cc w10-40 motor oil, do not apply grease here.
- 15) Apply a minimal amount of grease into spring fitting holes on Floating Ring back side, then carefully insert the 3 springs.
- 16) Insert Floating Ring into Hubshell Internal Splines.
- 17) Fully snap in Lip Seal (uncomplete/unaligned inserting voids its seal function).
- 18) Check again that the 3 springs are in their correct position.
- 19) Check that Floating Ring moves freely and quickly (press and release).
- 20) Apply 1cc of soft grease onto Freewheel Engagement Teeth.
- 21) Insert Freewheel, do not pinch Lip Seal.
- 22) Tighten Right Axle End at 9-10 Nm.
- 23) Check Preload Tuning (see below).
- 24) Install External OR (27x1.5 oiled) between Micro Tuner and bearing.

Extralite S12 Lock-Ring
12 Nm Max
 Never use original Shimano Lock-Ring

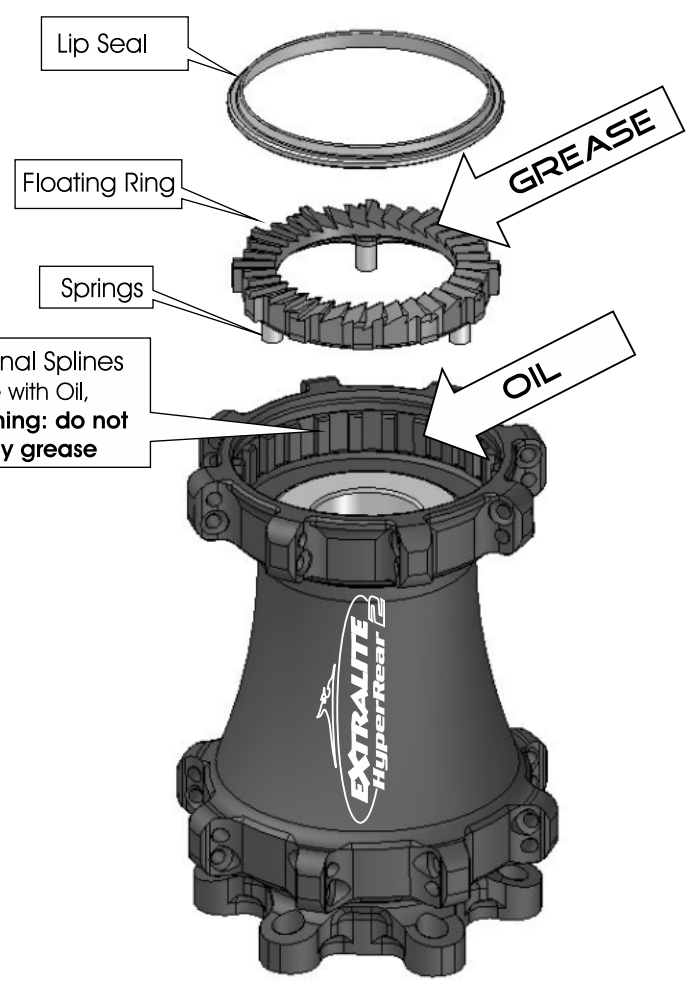

Preload Tuning

- If necessary fine tune as follows.
- 1) Install wheel into dropouts and normally lock skewer.
 - 2) If you feel play at the rim turn in Micro-Tuner (clockwise). Use a 21 mm wrench, very delicate torque and manners.
 - 3) Unscrew Micro-Tuner for ca 1/4 of turn to release excessive preload on bearing balls and achieve max rolling smoothness.
 - 4) Repeat Preload Checking and eventually slightly correct it.
 - 5) The optimal bearing preload cancels play at the rim without affecting rolling smoothness.

Warning Incorrect bearing preload can bring to serious damages:
 - Too tight --> bearings damage and premature wear
 - Too loose --> permanent freewheel damage

WARNING for Shima 12S compatible kit:

- Use only the supplied Extralite S12 Lock-Ring.
- Extralite freewheel body is not compatible with original Shimano Lock-Ring, never try to use it (will damage the thread)
- Extralite S12 lock ring employs a 0.5mm thin thread and should not be overtightened **Max tightening torque 12Nm**

