

# HyperCamber2+ 135 / 142mm

## FEATURES

HyperCamber2+ offers unique features like low friction external OR and lip seals, front engagement freewheel system, multishaped oversized axle, top quality sealed ball bearings, Micro-Tuner bearing preload system, "hart coat" anodized cassette body and axle ends.

Bearings: 2x 6903 2RS (hub body) and 2X 6803 2RS (freewheel). Use it proper care and its absolute performance will last for years. This manual provides the informations needed for the set up and the basic cleaning-lubing-maintenance.

**DESTINATION** X-Country use.

## DIMENSION FOR WHEEL BUILDING

Spoke hole Ø: 2.5mm

Right flange drilling Ø: 87-94mm

Disc flange drilling Ø: 53.6mm

Center to right flange: 22.5mm

Center to disc flange: 36.5mm

Secure disc bolts with mild threadlocker like Loctite 243

## LACING

See [www.extralite.com](http://www.extralite.com) to find spoke lengths. Respect 32h lacing pattern.

## MAXIMUM SPOKE TENSION No limitation

32H

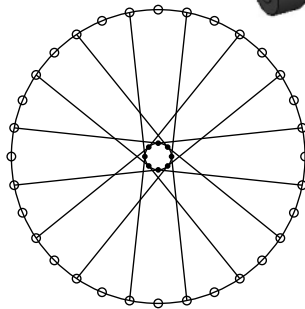

## BEARING PRELOAD SET-UP:

Optimal bearing preload is important for a long bearing life. Micro Tuner comes pre-adjusted from the factory. Do not modify its position if not necessary.

## Checking

Before modifying bearing preload carefully check the complete wheel as follows:

- 1) Install wheel into dropouts and normally lock skewer.
- 2) Check there is no play at rim diameter.
- 3) Leave wheel free to completely stop spinning and carefully control latest instants of movement. Stopping should be very smooth.

## Preload Tuning

If necessary fine tune as follows.

- 1) Install wheel into dropouts and normally lock skewer.
- 2) If you feel play at the rim turn in Micro-Tuner (clockwise). Use a 21mm wrench, very delicate torque and manners.
- 3) Unscrew Micro-Tuner for ca 1/4 of turn to release excessive preload on bearing balls and achieve max rolling smoothness.
- 4) Repeat Preload Checking and eventually slightly correct it.
- 5) The optimal bearing preload cancels play at the rim without affecting rolling smoothness.

## Warning Incorrect bearing preload can bring to serious damages:

- Too tight --> bearings damage and premature wear
- Too loose --> permanent freewheel damage

**SEALING** HyperCamber2+ hub features low friction Lip Seal and external OR seals. However, since it is impossible to completely seal a hub and still have it spin freely, with use water/moisture can get in.

**GUIDELINE** Periodically clean hub internals (every 6-12 months in normal and dry conditions, every 3 months in wet conditions and always before leaving the wheel un-used for more than 1 month) see Level1 instructions next page. Never use high-pressure spray washing directly on hubs. Clean hubs externally with warm water and soap.

**WARNING** Un-correct greasing and/or maintenance of freewheel mechanism can lock and destroy it!

**WARNING** Even small debris inside freewheel engagement can damage mechanism permanently.

**WARNING** Water and moisture stagnant inside hub can permanently damage bearings.

## Extralite Limited Warranty

Extralite products are warranted against defects in materials and/or workmanship for a period of two years from original date of purchase to the original owner only. Any Extralite product that is returned and found by Studio Riva to be defective in materials and/or workmanship will be repaired or replaced at the sole discretion of Studio Riva. This warranty is the sole and exclusive remedy. Studio Riva shall not be held liable for any indirect, special or consequential damages. The warranty is expressly limited to repair or replacement of the product that has been returned and found to be defective by Studio Riva and are the sole remedy of the warranty. No credits or refunds will be issued.

The warranty does not cover: normal wear, tear and fatigue; damage or failure due to accident or collision. Improper assembling, poor maintenance, alterations or modifications, installation of parts not compatible with Extralite products void this warranty. Warranty does not cover damage arising from crash, abuse and/or misuse or any other circumstances in which the product had been subjected to forces or loads beyond its design.

Immediately replace the component after crash and violent shock, or after continuous heavy use.

Improper use, modification and/or part changing, including surface finishing, could irreparably damage the component.

All labor charges for warranty service are responsibility of the product owner.

## INSTALLATION WARNING:

Extralite components are extremely performing and lightweight, crafted with very high quality, they request adequate installation and maintenance care. We strongly recommended that a professional bike shop install and service your Extralite components.

Improper assembly and/or adjustment may significantly compromise strength and durability of the component causing serious personal injury.

Carefully check proper tightening torque of every bolt. Always respect installation recommendations.

Extralite components are designed for a specific use X-Country or Road or Downhill, respect product specific destination.

Note: the rider assumes all the risks regarding use and installation of Extralite components.

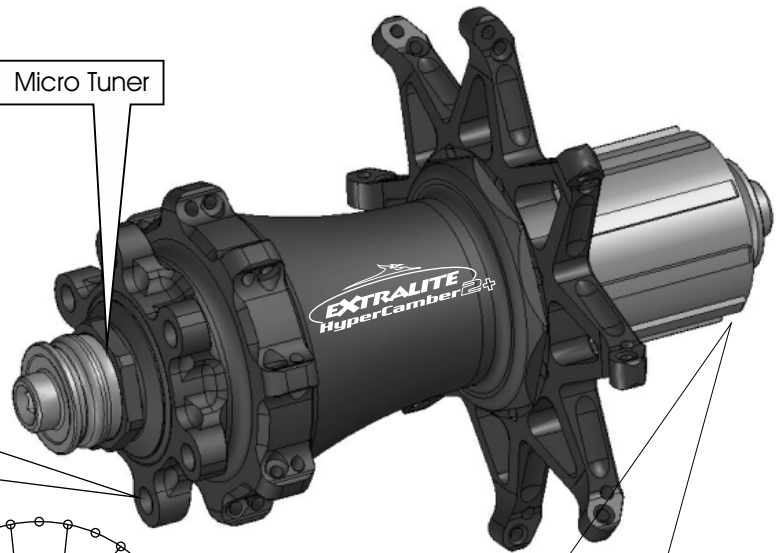

## Lock Ring maximum torque:

Shimano 10/M11s --> 25Nm

Shima 12s compatible --> 12 Nm

Use only Extralite S12 Lock-Ring  
Never use original Shimano Lock-Ring



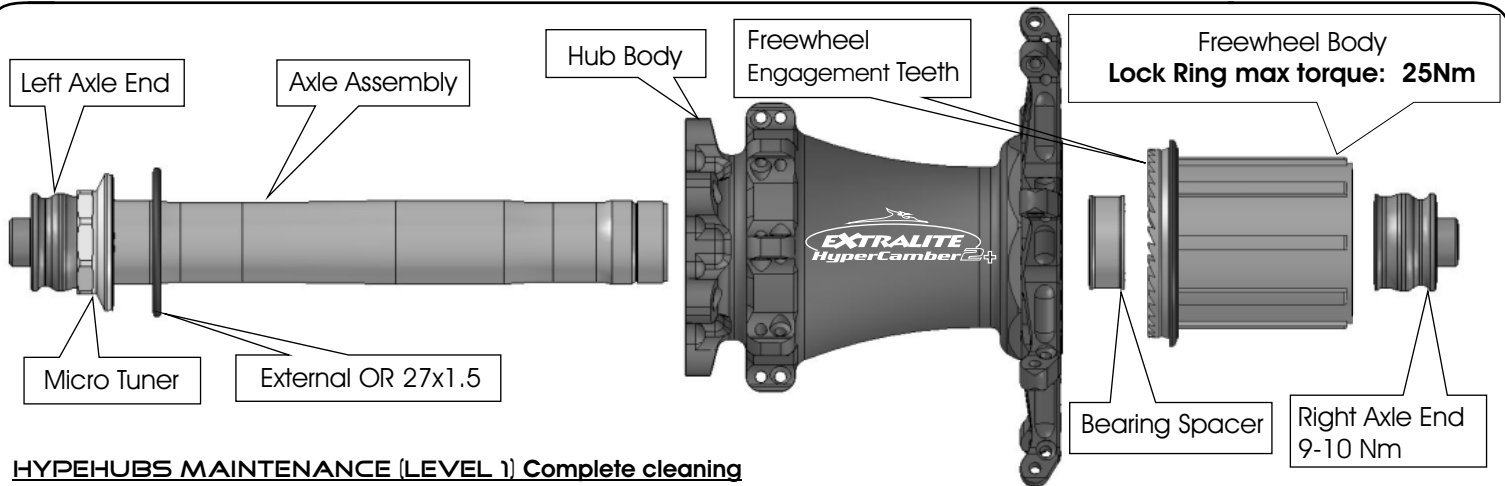

**HYPEHUBS MAINTENANCE (LEVEL 1) Complete cleaning**

Follow maintenance steps on a clean and well illuminated table since you'll have to handle tiny springs and delicate parts. Even small debris can compromise freewheel engagement mechanism. Water and moisture stagnant inside hub will damage bearings in few weeks.

**Disassembling**

- 1) Hold Left Axle End with a 17mm closed wrench (5mm hex wrench for 135mm).
- 2) Unscrew Right Axle End with another 17mm closed wrench (5mm hex wrench for 135mm).
- 3) Pull Freewheel Body and remove it.
- 4) Extract Bearing Spacer.
- 5) Remove Lip Seal from Hub Body.
- 6) Remove Floating Ring from Hub Body, you'll find 3 tiny springs on its back side.
- 7) Push out Axle Assembly and completely extract it from disc side.

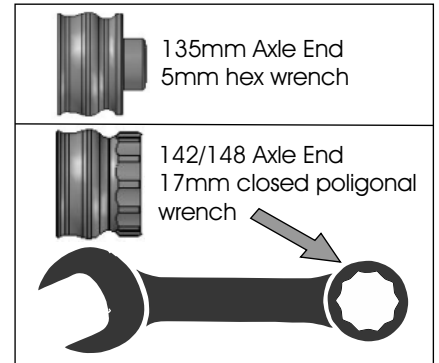

**Cleaning**

- 8) Clean all parts (Do not use aggressive solvents).
- 9) Clean very carefully Internal Splines, Floating Ring and Freewheel Teeth.

**Hubshell Splines Check - IMPORTANT!**

Once hub-shell internal is perfectly clean check well that every spline corner (clockwise corners) is still well square and flat.  
In case your hub has worn-out splines and you are not sure about it contact us [info@extralite.com](mailto:info@extralite.com) providing clear close-up photo.

**Potential risk**

When riding HyperHubs with dirt inside the hard particles of sand can badly grind the hubshell splines. Shortly the sand wears the hub-shell splines till the "floating ring" will not move freely anymore. This easily causes an uncomplete freewheel engagement and damages permanently the newly installed freewheel parts. In this case replacing "floating ring" and/or "Freewheel body" does not solve. The expensive hub-shell should be replaced (or eventually sent back for re-sharpening). For more detailed information check HyperHubs Tips on [extralite.com](http://extralite.com)

**Lubrification and reassembling**

**Warning:** use only very soft density grease as original Alugrease Super. Never use medium-dense or sticky grease since can slow down Floating Ring movement, this can destroy the freewheel mechanism! Chemical additives may damage O-rings and Lip Seal.

- 10) Grease Axle on bearing contact areas.
- 11) Fill up Micro Tuner internal face with soft grease.
- 12) Insert Axle Assembly from disc side.
- 13) Insert Bearing Spacer.
- 14) Oil Internal Splines of Hub Body with 1cc w10-40 motor oil, do not apply grease here.
- 15) Apply a minimal amount of grease into spring fitting holes on Floating Ring back side, then carefully insert the 3 springs.
- 16) Insert Floating Ring into Hubshell Internal Splines.
- 17) Fully snap in Lip Seal (uncomplete/unaligned inserting voids its seal function).
- 18) Check again that the 3 springs are in their correct position.
- 19) Check that Floating Ring moves freely and quickly (press and release).
- 20) Apply 1cc of soft grease onto Freewheel Engagement Teeth.
- 21) Insert Freewheel, do not pinch Lip Seal.
- 22) Tighten Right Axle End at 9-10 Nm.
- 23) Check Preload Tuning (see chapter).
- 24) Install External OR (27x1.5 oiled) between Micro Tuner and bearing.

