

HyperRear

Features

HyperRear offers unique features like low friction external OR seals, front engagement freewheel system, multishaped oversized axle, top quality sealed ball bearings, Micro-Tuner bearing preload system, "hart coat" anodized cassette body and axle ends.

Use it proper care and its absolute performance will last for years. This manual provides the informations needed for the set up and the basic cleaning-lubing-maintenance.

Destination X-Country use.

Dimension for wheel building

Spoke hole Ø: 2.5mm
Right flange drilling Ø: 50mm
Disc flange drilling Ø: 53.6mm
Center to right flange: 20.5mm
Center to disc flange: 34mm

Lacing

See www.extralite.com to find spoke lengths.
Respect 28h or 32h lacing patterns.

maximum spoke tension

Disc side 70kgf +/- 10kgf
Drive side 120kgf +/- 10kgf

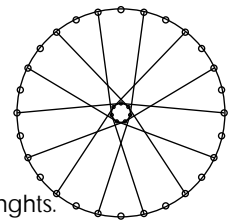

28H

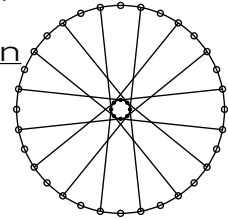

32H



Bearing preload set-up:

Optimal bearing preload is important for a long bearing life. Micro Tuner comes pre-adjusted from the factory. Do not modify its position if not necessary.

Checking

Before modifying bearing preload carefully check the complete wheel as follows:

- 1) Install wheel into dropouts and normally lock skewer.
- 2) Check there is no play at rim diameter.
- 3) Leave wheel free to completely stop spinning and carefully control latest instants of movement. Stopping should be very smooth.

Preload Tuning

If necessary fine tune as follows.

- 1) Install wheel into dropouts and normally lock skewer.
- 2) If you feel play at the rim turn in Micro-Tuner (clockwise). Use a 21mm wrench, very delicate torque and manners.
- 3) Unscrew Micro-Tuner for ca 1/4 of turn to release excessive preload on bearing balls and achieve max rolling smoothness.
- 4) Repeat Preload Checking and eventually slightly correct it.
- 5) The optimal bearing preload cancels play at the rim without affecting rolling smoothness.

Warning Incorrect bearing preload can damage bearings and freewheel parts additionally decreases hub performance.

Sealing HyperRear hub features low friction external OR seals. However, since it is impossible to completely seal a hub and still have it spin freely, with use water/moisture can get in.

Guideline Periodically clean hub internals (every 6-12 months in normal and dry conditions, every 3 months in wet conditions and always before leaving the wheel un-used for more than 1 month) see Level1 instructions next page. Never use high-pressure spray washing directly on hubs. Clean hubs externally with warm water and soap.

WARNING Un-correct greasing and/or maintenance of freewheel mechanism can lock and destroy it!

WARNING Even small debris inside freewheel engagement can damage mechanism permanently.

WARNING Water and moisture stagnant inside hub can permanently damage bearings.

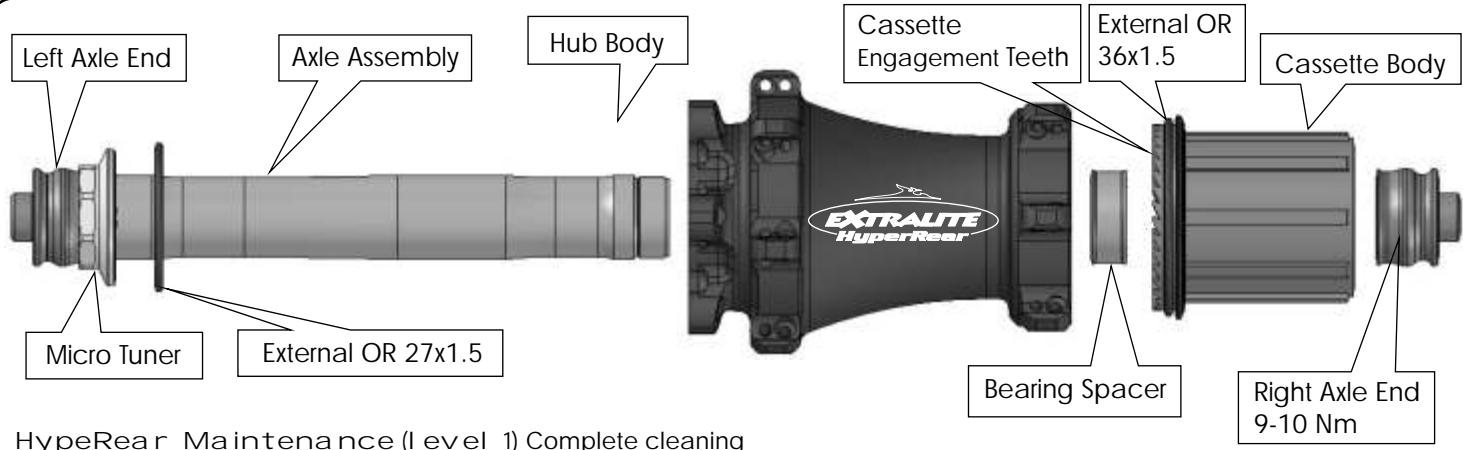

HyperRear Maintenance (Level 1) Complete cleaning
 Follow maintenance steps on a clean and well illuminated table since you'll have to handle tiny springs and delicate parts. Even small debris can compromise freewheel engagement mechanism. Water and moisture stagnant inside hub will damage bearings in few weeks.

Disassembling

- 1) Insert a 5mm hex wrench into Left Axle End.
- 2) Unscrew Right Axle End with another 5mm hex wrench.
- 3) Pull Cassette Body and remove it.
- 4) Extract Bearing Spacer.
- 5) Remove Retainer Ring from Hub Body.
- 6) Remove Floating Ring from Hub Body, you'll find 3 tiny springs on its back side.
- 7) Push out Axle Assembly and completely extract it from disc side.

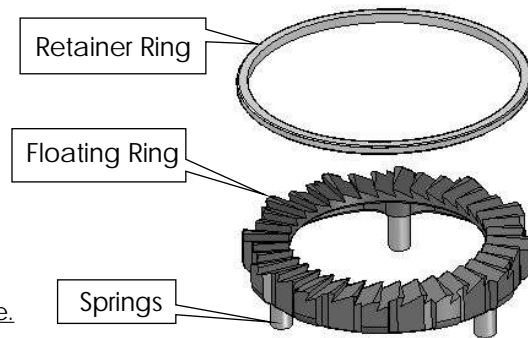

Cleaning

- 8) Clean all parts (Do not use aggressive solvents).
- 9) Clean very carefully Internal Splines, Floating Ring and Cassette Teeth
 Warning: even small debris can void freewheel engagement.
 Warning: check wear of Engagement Teeth: minimum teeth height 0.8mm, teeth edges should be sharp. If not replace: Springs/Cassette body/Floating Ring.

Internal Splines
 Lube with Oil,
 Warning: do not
 apply grease here



Lubrication and reassembling

- Warning: use only very soft density grease as original Alugrease Super1
 Medium-dense or sticky grease can lock or slow down Floating Ring movement, this can destroy the freewheel mechanism! Chemical additives may damage O-rings.
- 10) Grease Axle on bearing contact areas.
 - 11) Fill up Micro Tuner internal face with soft grease.
 - 12) Insert Axle Assembly from disc side.
 - 13) Insert Bearing Spacer.
 - 14) Oil Internal Splines of Hub Body with 1cc w30-50 motor oil.
 - 15) Apply a minimal amount of grease into spring fitting holes on Floating Ring back side, then carefully insert the 3 springs.
 - 16) Insert Floating Ring (check again that the 3 springs are in their correct position).
 - 17) Fully snap in Retainer Ring (uncomplete/unaligned inserting voids OR seal function)
 - 18) Check that Floating Ring moves freely and quickly.
 - 19) Apply 1cc of soft grease onto Cassette Engagement Teeth.
 - 20) Insert Cassette with External OR in position.
 - 21) Tighten Right Axle End at 9-10 Nm.
 - 22) Check Preload Tuning (see chapter).
 - 23) Install External OR (27x1.5 oiled) between Micro Tuner and bearing.



Extralite Limited Warranty

Extralite products are warranted against defects in materials and/or workmanship for a period of two years from original date of purchase to the original owner only. Any Extralite product that is returned and found by Studio Riva to be defective in materials and/or workmanship will be repaired or replaced at the sole discretion of Studio Riva. This warranty is the sole and exclusive remedy. Studio Riva shall not be held liable for any indirect, special or consequential damages. The warranty is expressly limited to repair or replacement of the product that has been returned and found to be defective by Studio Riva and are the sole remedy of the warranty. No credits or refunds will be issued.

The warranty does not cover: normal wear, tear and fatigue; damage or failure due to accident or collision. Improper assembling, poor maintenance, alterations or modifications, installation of parts not compatible with Extralite products void this warranty. Warranty does not cover damage arising from crash, abuse and/or misuse or any other circumstances in which the product had been subjected to forces or loads beyond its design.

Immediately replace the component after crash and violent shock, or after continuous heavy use.
 Improper use, modification and/or part changing, including surface finishing, could irreparably damage the component.
 All labor charges for warranty service are responsibility of the product owner.

INSTALLATION WARNING:

Extralite components are extremely performing and lightweight, crafted with very high quality, they request adequate installation and maintenance care. We strongly recommended that a professional bike shop install and service your Extralite components.

Improper assembly and/or adjustment may significantly compromise strength and durability of the component causing serious personal injury. Carefully check proper tightening torque of every bolt. Always respect installation recommendations.

Extralite components are designed for a specific use X-Country or Road or Downhill, respect product specific destination.
 Note: the rider assumes all the risks regarding use and installation of Extralite components.