

QRC-3S BSA 68mm BB T47

Read carefully instructions before installation

FRAME PREPARATION

Prepare BB shell:

- 1) BB shell faces should be parallel, $\pm 0.05\text{mm}$ tolerance.
- 2) BB shell faces should be at $68 \pm 0.2\text{mm}$.
Eventually file faces with appropriate tool.

3) Moisture draining: drill $\varnothing 3.5$ to 5mm drain hole.
Stagnant moisture or water will damage bearings in few weeks. Drilling might be not necessary only on sealed BB shell of monocoque frames.

WARNING: Incorrect / incomplete 1,2,3 set-ups can significantly reduce bearing life and performance.

DRIVE CRANK PREPARATION

Install chainring on the right crank with QRC3 Washer positioned between crank arm and chainring. You can remove QRC3 washer on thicker chainrings for better alignment.

Grease 5th Bolt thread and head, tight it at 5-6 Nm. Use only the supplied original QRC2 5th bolt (black). Install short male chainring bolts (we recommend ExtraBolt 1s and tight at 5-6 Nm).

FEATURES

Compatibility: BSA 68mm bb shell
Compact 110mm BCD single chainring
Chainline: 46mm
Q-Factor: 142mm

DESTINATION Road and Gravel use, single chainring setup

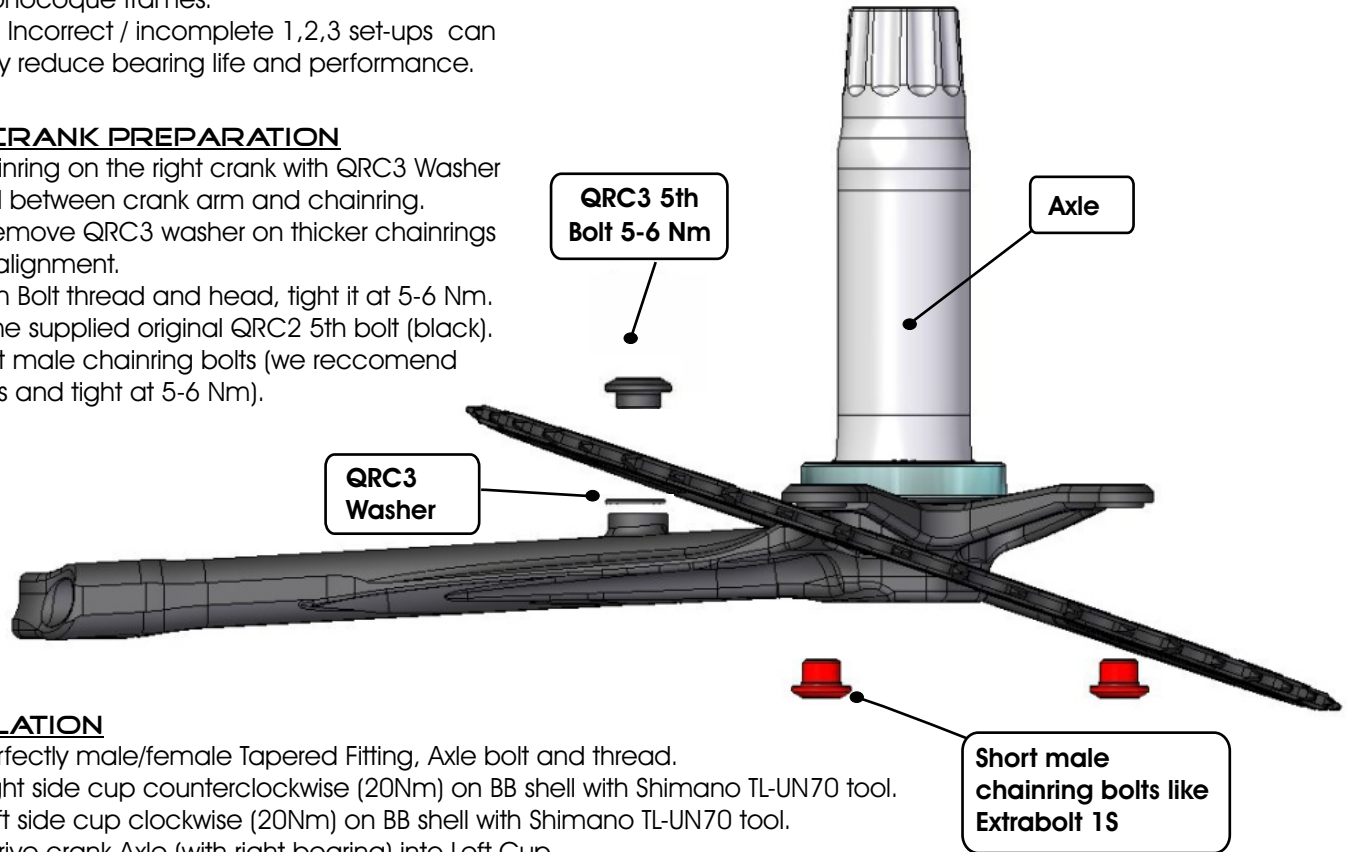

INSTALLATION

Clean perfectly male/female Tapered Fitting, Axle bolt and thread.

- 1) Tight right side cup counterclockwise (20Nm) on BB shell with Shimano TL-UN70 tool.
- 2) Tight left side cup clockwise (20Nm) on BB shell with Shimano TL-UN70 tool.
- 3) Insert drive crank Axle (with right bearing) into Left Cup.
- 4) Gently press it in with a small plastic mallet, completely insert it.
- 5) Insert Left Bushing onto Axle from left side end. Position it just between Axle and bearing inner race. Left crank will fully press in the bushing to its correct position, see point 8)
- 6) Grease Tapered Fitting and Axle Bolt thread.
- 7) Fully turn Bearing Preload Ring all way into the left crank lever (LOOSE direction) by hand.

WARNING: If you don't respect point 7) you'll damage Bearing Preload Ring thread.

- 8) Align left crank on Conical fitting, screw in Axle Bolt and tighten it (15Nm).
- 9) Adjust Bearing Preload Ring (see next page).

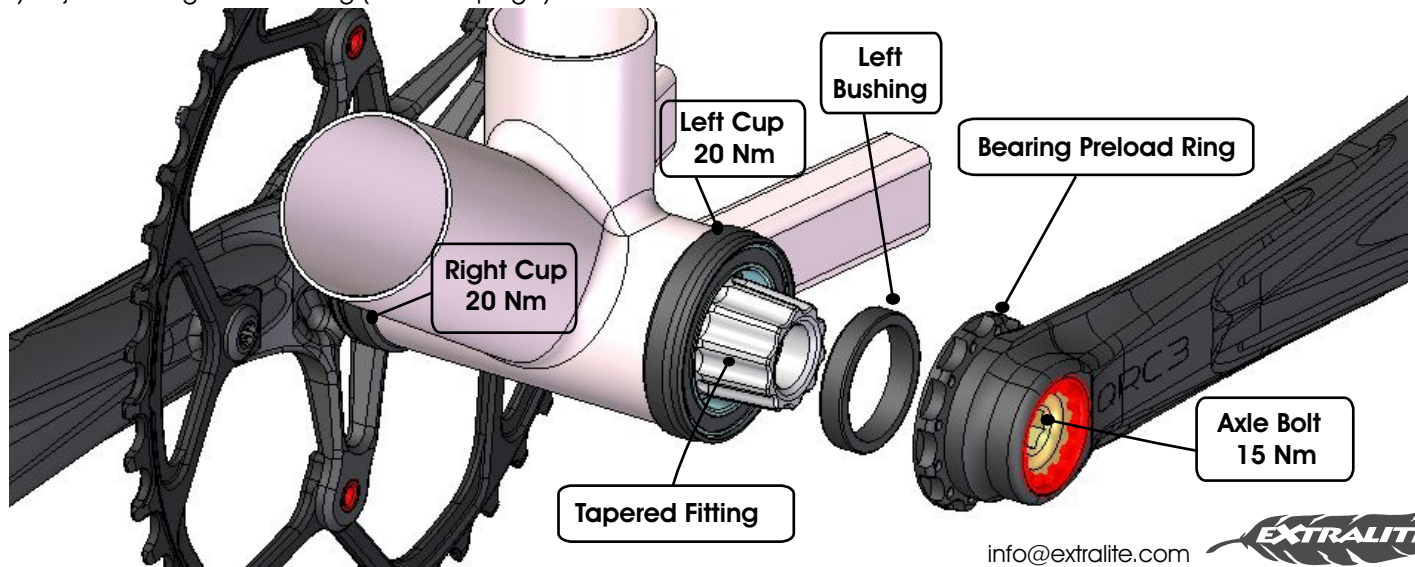

BEARING PRELOAD

Bearing Preload Ring allows precise adjustment of bearing axial preload.

After installation you always have to adjust bearing preload as follows.

Fully turn Bearing Preload Ring to FIRM direction by hand and then turn back 1-2 click to LOOSE direction.

Shake crank-end and check BB play.

Optimal tuning cancels axial play without adding any rolling resistance.

If necessary fine tune as follows:

FIRM --> to correct axial play.

<-- LOOSE to increase rolling smoothness.

WARNING: incorrect bearing preload may seriously damage bearings/parts and decreases performance.

REMOVAL

To disassemble left crank just fully unscrew Axle bolt.

To extract right crank and Axle pull it from right side. You can gently use a plastic mallet to push Axle from left side.

WARNING: keep all parts very clean especially male/female fittings of Hexagonal Cone, Axle bolt and threads.

Debris and dirt may seize alloy thin threads and/or damage Hexagonal Cone press fitting.

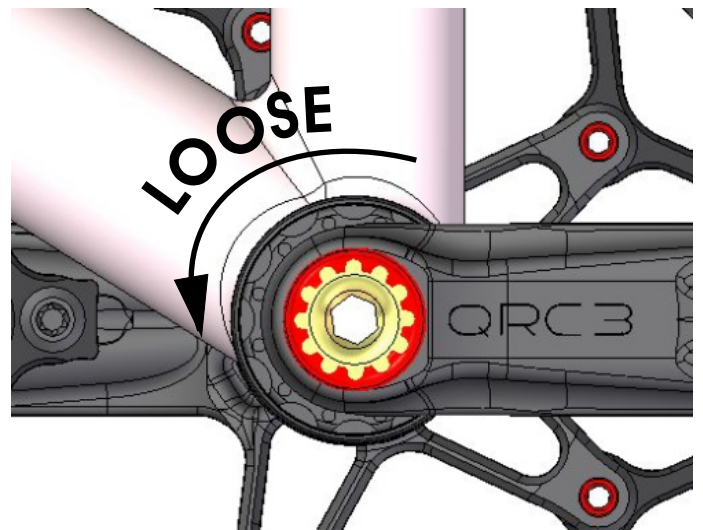
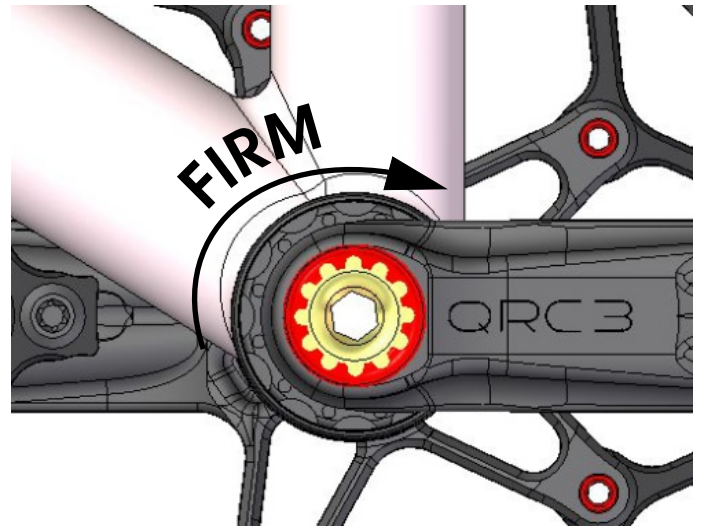

Extralite Limited Warranty

Extralite products are warranted against defects in materials and/or workmanship for a period of two years from original date of purchase to the original owner only.

Any Extralite product that is returned and found by Studio Riva to be defective in materials and/or workmanship will be repaired or replaced at the sole discretion of Studio Riva. This warranty is the sole and exclusive remedy.

Studio Riva shall not be held liable for any indirect, special or consequential damages.

The warranty is expressly limited to repair or replacement of the product that has been returned and found to be defective by Studio Riva and are the sole remedy of the warranty. No credits or refunds will be issued.

The warranty does not cover: normal wear, tear and fatigue; damage or failure due to accident or collision. Improper assembling, poor maintenance, alterations or modifications, installation of parts not compatible with Extralite products void this warranty.

Warranty does not cover damage arising from crash, abuse and/or misuse or any other circumstances in which the product had been subjected to forces or loads beyond its design.

Immediately replace the component after crash and violent shock, or after continuous heavy use.

Improper use, modification and/or part changing, including surface finishing, could irreparably damage the component.

All labor charges for warranty service are responsibility of the product owner.

INSTALLATION WARNING:

Extralite components are extremely performing and lightweight, crafted with very high quality, they request adequate installation and maintenance care.

We strongly recommended that a professional bike shop install and service your Extralite components.

Improper assembly and/or adjustment may significantly compromise strength and durability of the component causing serious personal injury.

Carefully check proper tightening torque of every bolt.

Always respect installation recommendations.

Extralite components are designed for a specific use X-Country or Road or Downhill, respect product specific destination.

Note: the rider assumes all the risks regarding use and installation of Extralite components.