

UltraLevers 2+

Read carefully instruction before installation

Leggere attentamente prima di procedere al montaggio

FEATURES

Material: special AL7075TX, GF30
Compatibility: grip and trigger shifters
Finishing: "hart coat" / black anodized
Graphics: laser etched
Destination: X-Country use, V-Brakes only

WARNINGS

Check that brakes are working properly before each ride. Never ride with brake levers loose or improperly adjusted. For safety reason do not alter any part of UltraLevers2+, neither surface finishing.
Replace immediately after bending or violent shock. Never try to straight bended parts.

INSTALLATION

Slide brake lever onto handlebar, be careful for top and bottom side (see pict.).
Tighten clamp screws with a Torx 10 hex wrench at very mild torque of 1,5Nm. Do not overtighten clamp bolts; this torque should keep UltraLevers2+ firm in all riding conditions and still enable them to slightly rotate on handlebar in case of crash.
Insert brake cable nut into lever hole.
Position cable adjuster about half way out.
Install cable into cable adjuster cut.
Install cable onto brakes following brake manufacturer indications.

TUNING

Lever positioning: screw in for shorter distance between lever and grip.
Unscrew cable preload control to tighten brake pad action.

SUGGESTIONS

Position you UltraLevers2+ to have maximum comfort (arm and fingers on same line) in attack position (standing on pedals).

CLEANING MAINTENANCE

Spray Wd40 or similar after every bike washing.
Occasionally clean lever pivot/bushing area as follow:
Remove cable from lever.
Remove safety O-ring.
Unscrew and remove lever pivot, use Torx T20.
Gently pull out lever bushing area (avoid spring overtensioning)
Clean bushings and pivot.
Reinstall lever pivot (check for correct bushing alignment)
Tighten mildly lever pivot (1,5Nm)
Reinstall safety O-ring
Reinstall and adjust brake cable.

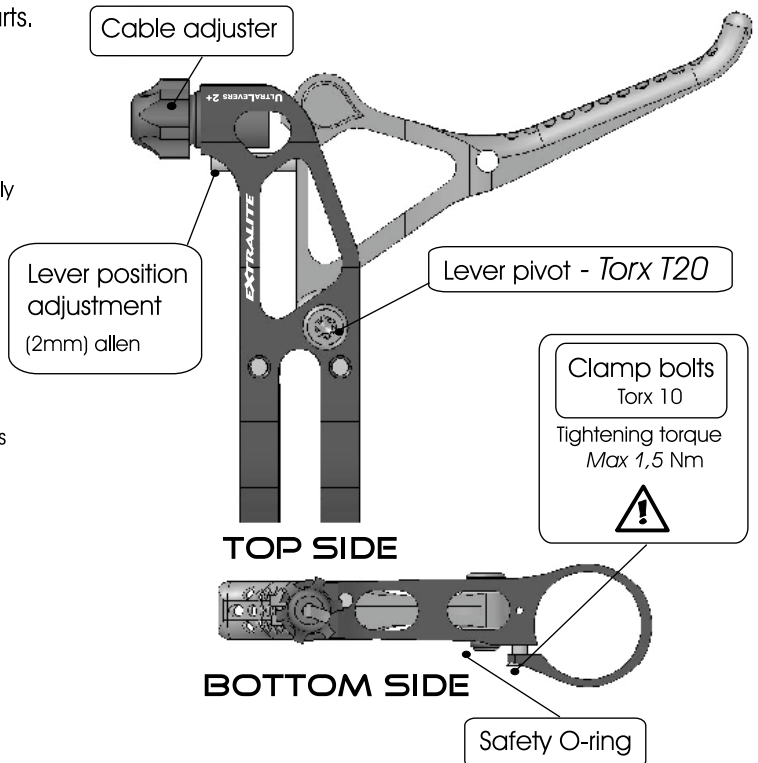

EXTRALITE

Extralite Limited Warranty

Extralite products are warranted against defects in materials and/or workmanship for a period of two years from original date of purchase to the original owner only.

Any Extralite product that is returned and found by Studio Riva to be defective in materials and/or workmanship will be repaired or replaced at the sole discretion of Studio Riva. This warranty is the sole and exclusive remedy. Studio Riva shall not be held liable for any indirect, special or consequential damages. The warranty is expressly limited to repair or replacement of the product that has been returned and found to be defective by Studio Riva and are the sole remedy of the warranty. No credits or refunds will be issued.

The warranty does not cover: normal wear, tear and fatigue; damage or failure due to accident or collision. Improper assembling, poor maintenance, alterations or modifications, installation of parts not compatible with Extralite products void this warranty. Warranty does not cover damage arising from crash, abuse and/or misuse or any other circumstances in which the product had been subjected to forces or loads beyond its design.

Immediately replace the component after crash and violent shock, or after continuous heavy use.

Improper use, modification and/or part changing, including surface finishing, could irreparably damage the component.

All labor charges for warranty service are responsibility of the product owner.

INSTALLATION WARNING:

Extralite components are extremely performing and lightweight, crafted with very high quality, they request adequate installation and maintenance care. We strongly recommended that a professional bike shop install and service your Extralite components. Improper assembly and/or adjustment may significantly compromise strength and durability of the component causing serious personal injury.

Carefully check proper tightening torque of every bolt. Always respect installation recommendations.

Extralite components are designed for a specific use X-Country or Road or Downhill, respect product specific destination.

Note: the rider assumes all the risks regarding use and installation of Extralite components.

EXTRALITE

Extralite Limited Warranty

Extralite products are warranted against defects in materials and/or workmanship for a period of two years from original date of purchase to the original owner only.

Any Extralite product that is returned and found by Studio Riva to be defective in materials and/or workmanship will be repaired or replaced at the sole discretion of Studio Riva. This warranty is the sole and exclusive remedy. Studio Riva shall not be held liable for any indirect, special or consequential damages. The warranty is expressly limited to repair or replacement of the product that has been returned and found to be defective by Studio Riva and are the sole remedy of the warranty. No credits or refunds will be issued.

The warranty does not cover: normal wear, tear and fatigue; damage or failure due to accident or collision. Improper assembling, poor maintenance, alterations or modifications, installation of parts not compatible with Extralite products void this warranty. Warranty does not cover damage arising from crash, abuse and/or misuse or any other circumstances in which the product had been subjected to forces or loads beyond its design.

Immediately replace the component after crash and violent shock, or after continuous heavy use.

Improper use, modification and/or part changing, including surface finishing, could irreparably damage the component.

All labor charges for warranty service are responsibility of the product owner.

INSTALLATION WARNING:

Extralite components are extremely performing and lightweight, crafted with very high quality, they request adequate installation and maintenance care. We strongly recommended that a professional bike shop install and service your Extralite components. Improper assembly and/or adjustment may significantly compromise strength and durability of the component causing serious personal injury.

Carefully check proper tightening torque of every bolt. Always respect installation recommendations.

Extralite components are designed for a specific use X-Country or Road or Downhill, respect product specific destination.

Note: the rider assumes all the risks regarding use and installation of Extralite components.

Studio Riva S.r.l. - Tel: ++39 0371 203059
info@extralite.com - www.extralite.com

EXTRALITE

UltraLevers 2+

Read carefully instruction before installation

Leggere attentamente prima di procedere al montaggio

FEATURES

Material: special AL7075TX, GF30

Compatibility: grip and trigger shifters

Finishing: "hart coat" / black anodized

Graphics: laser etched

Destination: X-Country use, V-Brakes only

WARNINGS

Check that brakes are working properly before each ride. Never ride with brake levers loose or improperly adjusted. For safety reason do not alter any part of UltraLevers2+, neither surface finishing.

Replace immediately after bending or violent shock. Never try to straight bended parts.

INSTALLATION

Slide brake lever onto handlebar, be careful for top and bottom side (see pict.).

Tighten clamp screws with a Torx 10 hex wrench at very mild torque of 1,5Nm. Do not overtighten clamp bolts; this torque should keep UltraLevers2+ firm in all riding conditions and still enable them to slightly rotate on handlebar in case of crash.

Insert brake cable nut into lever hole.

Position cable adjuster about half way out.

Install cable into cable adjuster cut.

Install cable onto brakes following brake manufacturer indications.

TUNING

Lever positioning: screw in for shorter distance between lever and grip.

Unscrew cable preload control to tighten brake pad action.

SUGGESTIONS

Position you UltraLevers2+ to have maximum comfort (arm and fingers on same line) in attack position (standing on pedals).

CLEANING MAINTENANCE

Spray Wd40 or similar after every bike washing.

Occasionally clean lever pivot/bushing area as follow:

Remove cable from lever.

Remove safety Oring.

Unscrew and remove lever pivot, use Torx T20.

Gently pull out lever bushing area (avoid spring overtensioning)

Clean bushings and pivot.

Reinstall lever pivot (check for correct bushing alignment)

Tighten mildly lever pivot (1,5Nm)

Reinstall safety Oring

Reinstall and adjust brake cable.

